

HYDROGENERATOR POD 600

Installation and instruction manual

Version	V3
Date	MAY 2023
Contact	contact@wattandsea.com

Congratulations!

You have just purchased the most powerful hydrogenerator of its kind. Inspired by the requirements of ocean racing yachts, designed to resist the stresses experienced by monohulls, this hydrogenerator will radically change your energy management at sea and become your main source of power while sailing.

This product has been thoroughly inspected. The product comes with the WATT&SEA warranty described in the "Warranty Terms" chapter of this installation guide. For traceability under the warranty, please register the product on our website: www.wattandsea.com

Designed & manufactured in France by:

WATT&SEA SARL
3, rue Jacques Cartier
17000 La Rochelle
France

www.wattandsea.com

TABLE OF CONTENTS

1.	SAFETY PRECAUTIONS	3
1.1.	ELECTRICAL HAZARDS	3
1.2.	INSTALLATION	3
1.3.	OPERATION	3
2.	CONTENTS OF THE HYDROGENERATOR PACK	4
3.	ADDITIONAL EQUIPMENT REQUIRED	4
4.	MECHANICAL INSTALLATION	5
4.1.	POSITIONING BELOW THE HULL	5
4.2.	DESIGNING THE DRILLING TEMPLATE	5
4.3.	FIXING BELOW THE HULL	5
4.4.	PROTECTION / ANTI-FOULING	7
4.5.	ASSEMBLING THE PROPELLER	7
4.6.	DISMANTLING THE PROPELLER	8
4.7.	MOUNTING THE ELECTRONIC CONVERTER	9
4.8.	FINAL CHECK	9
5.	ELECTRICAL INSTALLATION	11
5.1.	THREE-PHASE WIRING OF THE HYDROGENERATOR	12
5.2.	CABLING FOR THE ON/OFF RELAY	12
5.3.	USING A SOLAR PANEL	12
5.4.	CONNECTING THE CONVERTER TO THE BATTERIES	13
5.5.	INTERPRETATION OF THE CONVERTER'S LEDs	15
5.6.	BLUETOOTH	16
6.	SPECIFICATIONS	17
6.1.	POD 600 TECHNICAL CHARACTERISTICS	17
6.2.	OPERATING PRINCIPLES	18
7.	MAINTENANCE	19
8.	F.A.Q.	20
8.1.	OPERATION	20
9.	WARRANTY	21
10.	FORM FOR REQUESTING AN AFTER-SALES SERVICE RETURN	22

1. SAFETY PRECAUTIONS

While our primary concern in designing the hydrogenerator was your safety, certain precautions must nevertheless be taken when operating any mechanical or electrical equipment.

Please keep the following safety factors in mind when installing and operating the hydrogenerator, and be aware at all times of the electrical and mechanical hazards inherent in operating the propeller.

MECHANICAL HAZARDS

The hydrogenerator's blades are made of a composite material and can rotate at a speed of over 100 km/h (62 mph).

At this speed, the blades are practically invisible and can cause serious injury.

WARNING: WHEN INSTALLING THE HYDROGENERATOR, MAKE SURE THAT THE PROPELLER IS SAFELY POSITIONED OUT OF REACH. DO NOT ATTEMPT TO STOP THE PROPELLER WITH YOUR HAND WHILE THE GENERATOR IS RUNNING.

1.1. Electrical hazards

Heat in wiring systems often results from undersized cables or faulty connections.

Batteries have a very high current-carrying capacity. A short-circuit in their cables may result in an outbreak of fire. To prevent this hazard, you must install a 50 amp fuse between the converter and each battery.

If the fuse is defective, you must determine the reason before resetting or replacing it.

WARNING: YOU MUST INSTALL AN EXTERNAL 50 AMP FUSE.

1.2. Installation

Please observe the following precautions during installation:

- Keep safety in mind at all times! Have someone help you throughout the duration of the installation.
- Remember: the batteries should be connected last.

1.3. Operation

- Check the support structure, blades and electric circuits on a regular basis.
- Although the propeller blades are made of very strong materials, they may warp or break if they come into contact with a submerged object.

WARNING: NEVER TOUCH THE PROPELLER WHEN IT IS SPINNING.

WARNING: WHEN RUNNING, THE CONVERTER CAN REACH VERY HIGH TEMPERATURES.

2. CONTENTS OF THE HYDROGENERATOR PACK

Check the contents of your pack against the list below:

- 1 HYDROGENERATOR with 5 metres of cable
 - o 2 M8 stainless steel anchors
 - o 2 rubber soles
 - o 1 stainless steel backplate
 - o 8x10mm insulation tubes for metallic hulls
 - o 2 spacers
- 1 THREE-BLADE PROPELLER 240mm extraction kit
- 1 RELAY 12 or 24V upon battery voltage
- 1 CONVERTOR (CV-03) with bag of connectors:
 - o 1 hydrogenerator connector
 - o 1 solar connector
 - o 3 battery connectors
- 1 INSTRUCTION MANUAL
- 2 STICKERS for the hull



The pack and its contents

3. ADDITIONAL EQUIPMENT REQUIRED

- Three-phase cable, minimum 3 x 1.5 mm², for connecting the hydrogenerator to the converter (if length <10m, otherwise please use a bigger section of 2,5mm²)
- Red and black 10 mm² cable for connecting the batteries
- 2.5mm² cable to short circuit the relay
- Joint connectors for the 10 mm² battery cable
- 50 amp fuse or thermal circuit breaker (e.g. Series 187 from Blue Sea Systems)
- 1 ON/OFF switch for the chart table
- 1 x 1 amp fuse to protect this switch
- 10 fast-on 6.35 mm lugs and crimping tool
- Waterproof bonding sealant (e.g. Sikaflex 291)

4. MECHANICAL INSTALLATION

Your hydrogenerator is shipped partially disassembled. Please read the instruction manual carefully before starting installation.

4.1. Positioning below the hull

This hydrogenerator is designed to work in the wake of a fixed appendage, such as a keel or centreboard, so it is protected from logjams. It has not been designed to work behind a mobile appendage (rudder, engine propeller, ...).

To maximise its output, the device should be aligned with the boat axis.

The device should be fixed in an area free of supports with a minimum dimension of 230x60mm

The hull must be 18 mm thick minimum. If the hull is thinner than this, a small shim must be added to ensure the fixing anchors function correctly. The maximum thickness for the hull should not be greater than 50mm.

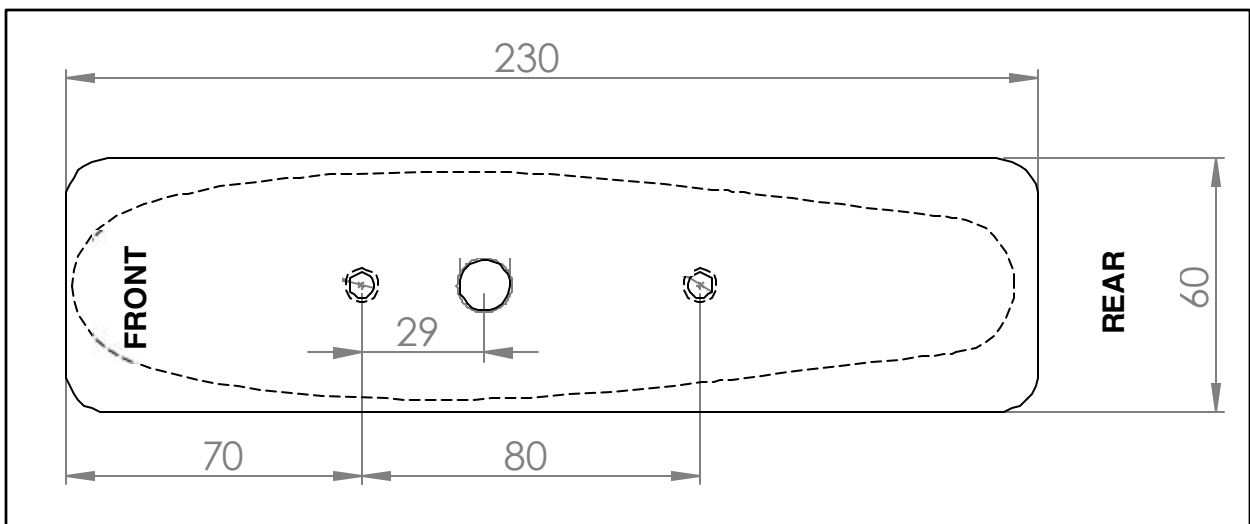

Product plan seen from above (dimensions in mm)

4.2. Designing the drilling template

In order to drill well vertical, it is suggested to build a template in a piece of wood - 30mm thickness – with 3 holes of 8 mm spaced of 29 mm and 51 mm (see drawing above). A better result will be obtained on a drill press.

4.3. Fixing below the hull

- Clean the area below the hull where the product will be fixed
- **Drill 3 holes final diameter 10 mm** thanks to the template
- Cut the plastic tubes that will isolate the hull from the metallic rods to the right length
- Trial-fit the product
- Prepare the interior surface for adhering
- Stick the rubber sole to the interior of the boat, ensuring it is watertight
- Stick the stainless steel backplate on top of it, also ensuring it is watertight
- Stick the gasket in the sealing thread
- Pass the electric cable through the gasket (remove the seal and plastic handle beforehand)

PLEASE DO NOT GLUE THE CABLE OR INSERT MASTIC INSIDE THE 90° FITTING OTHERWISE THE PRODUCT WILL BE UNREMOVABLE FOR FUTURE SERVICE

- Fit the device fitted with the rubber sole
- Install the lock washer Heico-Lock as per below diagram :

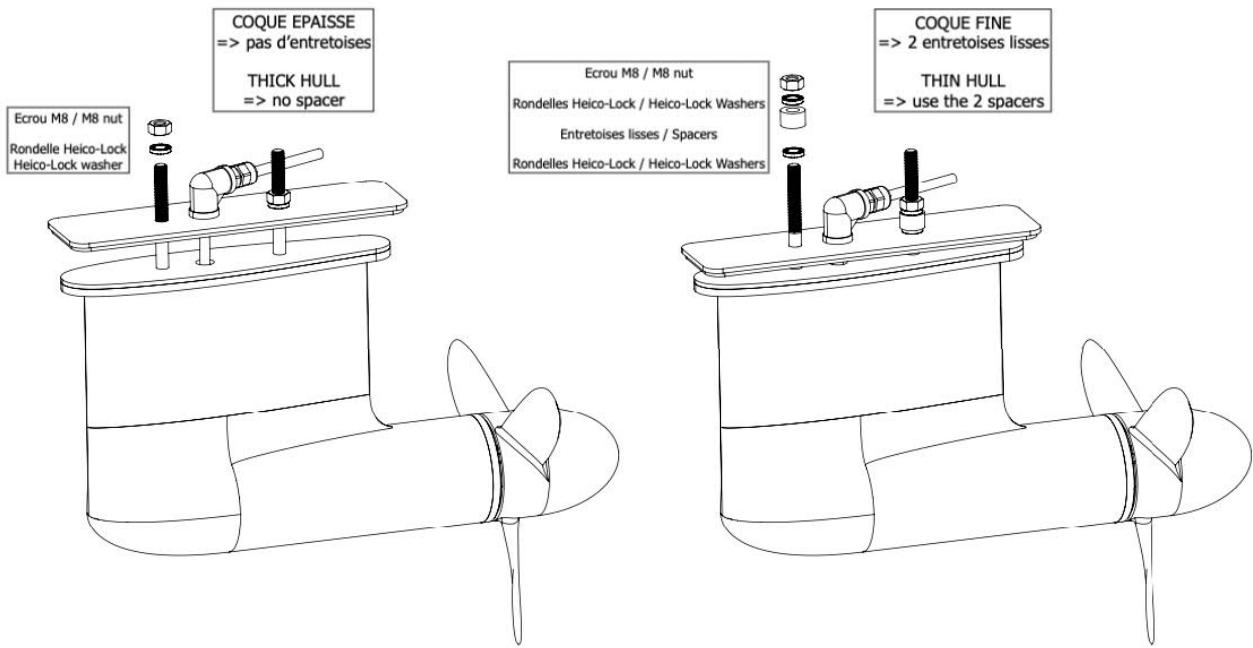

- Bolt it to the interior of the hull and use sealant to ensure the threaded rods are watertight

CAUTION to specific cases :

Sandwich hull : the holes must be densified and made waterproof to avoid infiltrations inside the core.

Metallic or carbon hull : the stainless steel rods must be insulated with the provide plastic tube.

Please check the insulation between rods and hull with a multimeter during trial fit.



4.4. Protection / anti-fouling

The device can be coated with a thin anti-fouling paint that is compatible with aluminium (for example AT7.Speed/NAUTIX or Aqualine Optima/JOTUN ...)

For hulls protected with copper anti-fouling, please use an anti-fouling compatible with aluminium (as for saildrives).

CAUTION : DO NOT USE A COPPER BASED PAINT ON THIS DEVICE

4.5. Assembling the propeller

- Slide the propeller onto the drive shaft.
- Check that the stainless steel washer (3) has been pre-mounted at the end of the propeller. If not, insert it.
- Insert the HSHC M5x20 screw (4)
- Hold the propeller with one hand and tighten the screw using the 4 mm (5/32") Allen key until the screw starts turning the propeller.

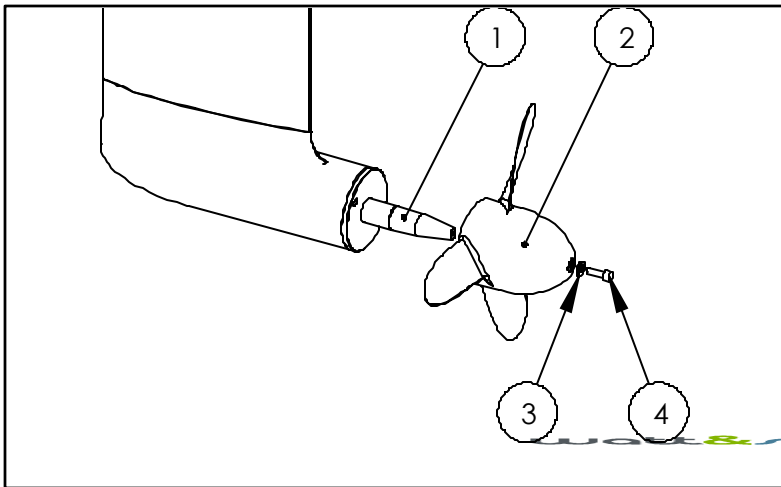

N	Designation
1	Drive shaft
2	Three-blade propeller
3	Stainless steel washer
4	M5x20HSHC screw

Exploded view of the drive shaft, propeller, washer and M5 screw

4.6. Dismantling the propeller

To dismantle the propeller, use the M6 extractor screw (supplied with the hydrogenerator).

- Unscrew the M5 screw that holds the propeller at the end of the drive shaft.
- In its place, insert the M6 screw and tighten it using the appropriate key. This will effortlessly remove the propeller from its conical fitting.

N.B.: Any method for dismantling the propeller other than the one described above may result in damage to the hydrogenerator.

4.7. Mounting the electronic converter

The electronic converter is a box which is resistant to water splashes and passive ventilation, guaranteeing long-term protection even in humid environments.

The converter must nevertheless be installed inside the boat, preferably in the mechanical room in close proximity to the batteries.

WARNING: WHEN RUNNING, THE CONVERTER CAN REACH VERY HIGH TEMPERATURES. AS SUCH, ASSEMBLY SHOULD BE CARRIED OUT IN A VENTILATED SPACE.

**N.B.: To ensure proper ventilation, the converter must be mounted on a vertical bulkhead, with the ventilation grids in a vertical position.
If you wish to have access to the status of the inverter, consider leaving visual access to the LEDs on the top (white cover).**



As it is so light, the converter can be securely attached using the Velcro provided.

- Degrease the surface on which the converter will be installed
- Remove the protective tabs on the strips of Velcro provided on the converter
- Apply the quick-drying glue if the surface is very uneven (plywood, fibreglass, etc.)
- Firmly attach the converter to the surface

4.8. Final check

Before putting the boat back in the water we advise you to perform a drill test according to the following procedure:

- Procedure :
 - Make sure that battery is not fully charge
 - Disconnect the solar panels from the converter
 - Unmount the propeller from the hydrogenator
 - Mount a similar screw at shaft end (CHC M5x20)
 - Rotate the shaft clockwise with an electric screwdriver (please take care not to damage head screw)
 - Observe converter LEDs and boat amp-meter
- Results :
 - The drill should force a little but rotate smoothly
 - The converter LEDs should switch from stand-by mode (colored pulsations green to red depending of battery voltage) to charge mode (fix color purple)
 - The amp-meter should show a 3 to 10A production in 12V (half less in 24V), depending on which

Double-check the waterproofness once the boat is back in water.

We advise to put above the waterline the provided stickers that locate the device to avoid future damages during craning.

On metallic or carbon hulls, please check the absence of continuity between the rods and the hull.

WARNING : THE DEVICE WILL BE DESTROYED IF TAKEN UNDER THE TRAVELIFT STRAPS

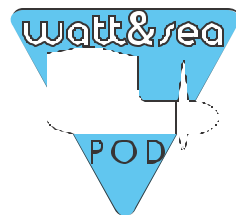

5. ELECTRICAL INSTALLATION

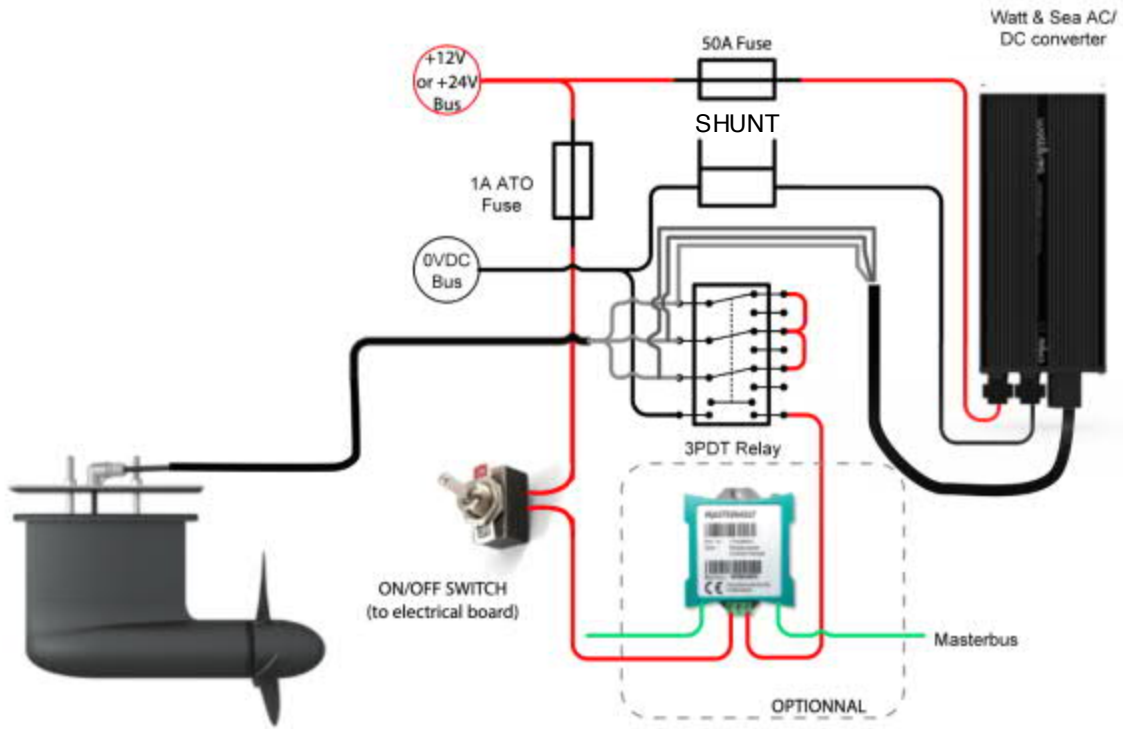

Wiring principle

Recommendations regarding electric connections:

Please consult local/national safety rules before installation.

All electric cables must be carefully insulated. For maximum protection, cover the cables with electrical cable sheaths.

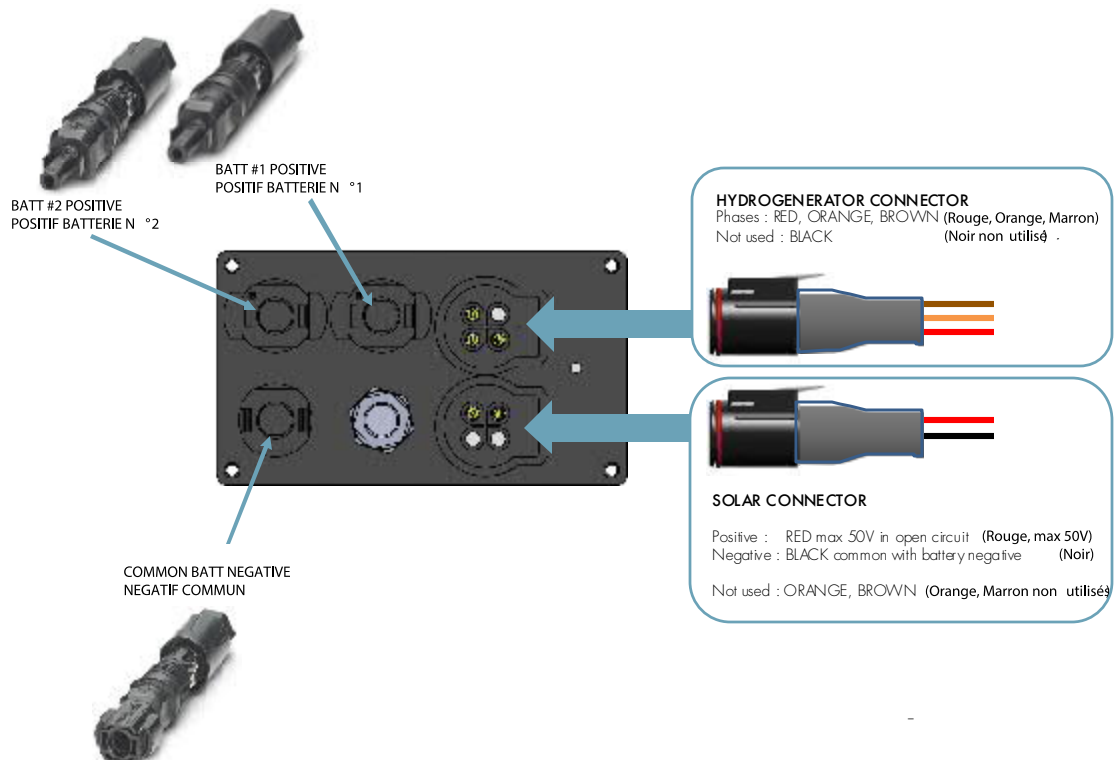

Converter connection

5.1. Three-phase wiring of the hydrogenerator

The hydrogenerator is fitted with a small diameter electrical cable of sufficient length to pass through the boat. This is a three-phase cable. If you need to extend it, it must be at least 3x1.5 mm².

Then connect the 3 phases to one of the sockets supplied, ensuring you do not use the black conductor. There is no order to follow when connecting the other conductors (brown, orange, red). You could use *WAGO 222* connectors, for example.



Connect this socket to the input labelled “HYDRO”

N.B.: The phase sequence is irrelevant. There is thus no need to take into account the colour or numbering of the cables.

5.2. Cabling for the on/off relay

In order to stop energy production and slow the device down, an on/off relay of 12 V or 24 V is available.

Cable this relay using *fast-on 6.35 mm* lugs as follows:

A-B: 12 V or 24 V relay supply via the chart table switch (not supplied), protected by a fuse.

1-2-3: connect together (use 2,5mm² section wire)

4-5-6: not connected

7-8-9: connect to each of the hydrogenerator's phases

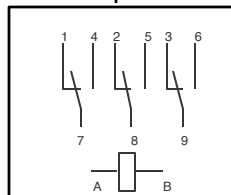

Relay schematic drawing

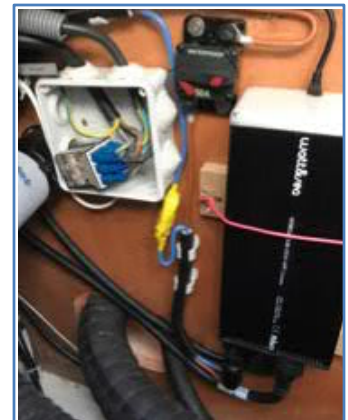

5.3. Using a solar panel

The converter has a second input for a solar panel. The solar panel's maximum voltage must not exceed 50 VCC and the intensity must not exceed 14 amps. The minimum voltage at which the converter can start charging is 7.5 VCC.

When the hydrogenerator and the solar panel generate power at the same time, priority is given to the hydrogenerator. As soon as it stops generating power (stopped, the boat is moored, etc.) the converter automatically takes into account the solar panel's charge.

Connect the solar panel to the second moulded socket supplied, while observing the following polarity:

- **NEGATIVE SOLAR: BLACK**
- **POSITIVE SOLAR (50 V max): RED**

Connect this socket to the input labelled “SOLAR”

WARNING: OBSERVE THE POLARITY OF THE SOLAR PANEL

5.4. Connecting the converter to the batteries

The converter must be placed as close as possible to the batteries in order to minimise losses due to cable length. The maximum recommended distance is 2 metres.

The batteries are connected to the converter via a solar connector.

The converter has an internal 2-path balancer that makes it possible to charge two battery units separately. The 2 battery units must be at the same voltage.

WARNING: RISK OF OVERLOADING AND FIRE. THE TWO BATTERY UNITS MUST BE THE SAME TYPE AND HAVE THE SAME VOLTAGE

WARNING: EACH BATTERY UNIT MUST BE PROTECTED WITH A 50 AMP FUSE

We recommend connecting the hydrogenerator's converter directly to the auxiliary battery unit. The converter will monitor the batteries independently of the other on-board units and will charge them as and when required.

N.B.: Proper operation on one external charge balancer is not guaranteed and may require additional adjustment. Please contact your distributor.

WARNING: NEVER REVERSE THE POLARITY OF THE CONVERTER. THIS WILL LEAD TO THE DESTRUCTION OF THE DEVICE.

Fitting / removing the battery connectors:

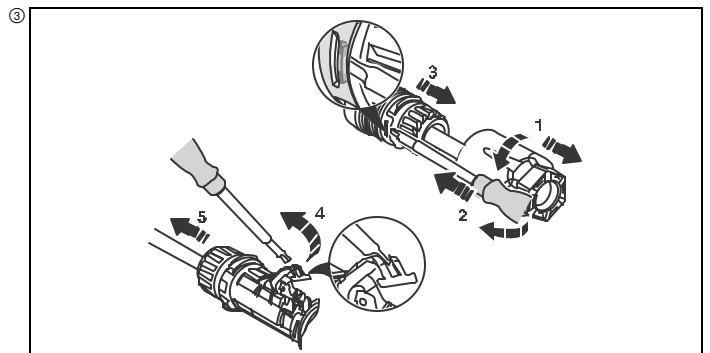
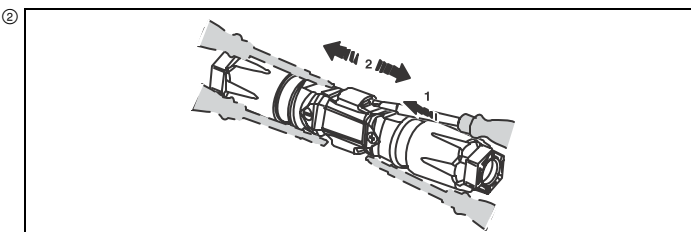
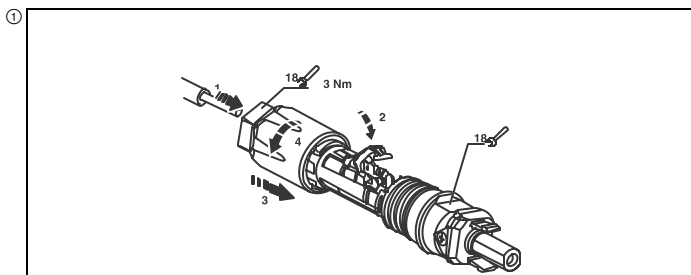

Instructions for connectors used to connect the batteries:

English

SUNCLIX photovoltaic I/O connector for installation in photovoltaic systems for 6 ... 16 mm² solar cables, type PV1-F

1 Safety notes



WARNING: The SUNCLIX plug-in connectors may be connected only by trained electricians.



WARNING: Never plug in or disconnect the SUNCLIX plug-in connectors under load.



NOTE: Use these plug-in connectors only in combination with a 6 ... 16 mm² solar cable, type PV1-F. A safe, electrical connection is only possible with this cable. When laying out the cable, observe the bending radiuses that the manufacturer specifies.



NOTE: Connect this plug-in connector only with other SUNCLIX photovoltaic plug-in connector. When making the connections, be sure to observe the specifications on nominal voltage and nominal current. The smallest common value is permissible.



NOTE: Protect the plug-in connectors from humidity and dirt.

- Do not immerse the plug-in connector in water.
- Never lay out the plug directly on the roofing.
- Attach a protective cap (e.g. PV-C PROTECTION CAP, order number 1785430) to plug-in connectors that are not plugged in.

2 Connecting connectors

You need a slot screwdriver with a 3-mm wide blade (e.g. SZF 1-0.6X3.5; item no. 1204517).

2.1 Connecting the cable (Fig. ①)

- Strip the cable by 18 mm with a suitable tool. Make sure that no individual wires are cut off.
- 1 Carefully insert the stripped wire all the way in. The litz wire ends have to be visible in the spring.
 - 2 Close the spring. Make sure that the spring is snapped in.
 - 3 Push the insert into the sleeve.
 - 4 Tighten the cable gland to 3 Nm.

2.2 Assemble the connector

- Bring the plug and the socket together. The connection snaps close thereby.
- Pull on the coupling to check the proper connection.

3 Separating the connector (Fig ②)

- 1 Insert the screwdriver as shown in Fig. ②.
- 2 Leave screwdriver inserted and disconnect the plug and the socket from each other.

3.1 Loosen the cable (Fig. ③)

- 1 Screw open the cable gland.
- 2 Insert the screwdriver at the position shown in Fig. ③.
- 3 Pry the connection open and pull the sleeve and the insert apart.
- 4 Open the spring with the screwdriver.
- 5 Remove the cable.

4 Technical data

Ambient temperature: -40 °C ... +90 °C

Nominal voltage: max. 1500 V DC

Nominal current: 40 A (6 mm²), 50 A (10 mm²), 65 A (16 mm²)

Cable diameter: 5,5 ... 10 [mm]

5.5. Interpretation of the converter's LEDs

- When the converter **is not charging**, the battery power is indicated by a **pulse** of colour which changes from green (12.8 V) to red (11.5 V).

- When the converter **is charging**, the output power is indicated by a **constant colour** which changes from violet to blue (120 W), to light blue (240 W) and finally to white (480 W).

- Green or red coloured **flashes** may **overlay** the display of the constant colour to indicate statuses or anomalies:

SITUATION	VISUAL	COMMENTS
End of charge voltage reached	1 brief green flash every 5 seconds	The battery is full (end of charge voltage = 14.3 V / 28.6 V)
Maintenance voltage maintained	1 long green flash every 5 seconds	The battery is kept at 100% (maintenance voltage = 13.8 V / 27.6 V)
Overheating	1 red flash every 5 seconds	The maximum box temperature has been reached
Generator anomaly	2 red flashes every 5 seconds	The hydrogenerator's connection is defective
Overvoltage at input	3 red flashes every 5 seconds	The solar panel or the hydrogenerator are applying a voltage that is too high
Other anomaly	4 red flashes every 5 seconds	Contact your reseller

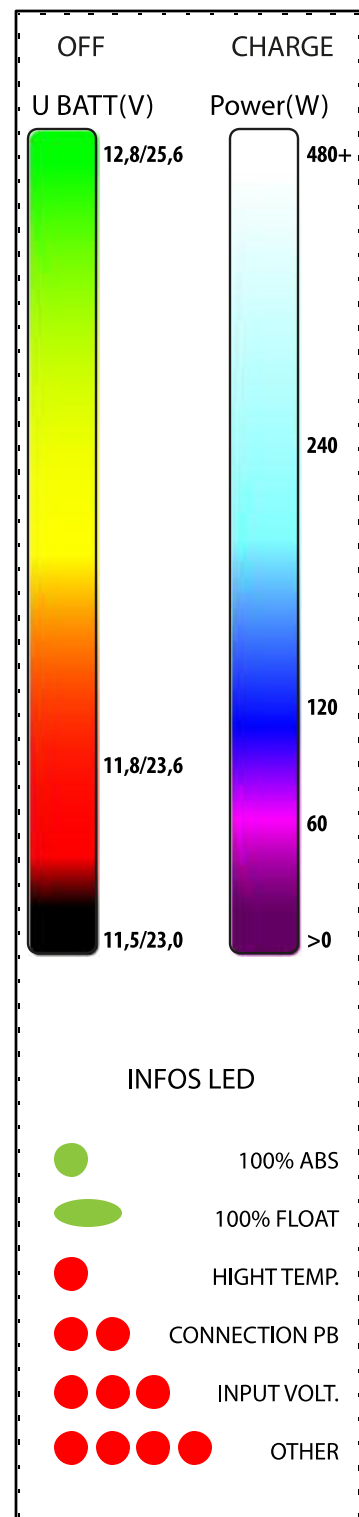

5.6. Bluetooth

Since the end of 2019, Watt&Sea converters embed a Bluetooth chip (serial numbers above CV-03-1630).

The Watt&Sea application is available on Appstore® and Google Play®. It will allow you to track your hydrogenerator's production, make data records, and adjust charging settings.

To install and use the application:

- Download the application on Appstore® or Google Play®
- Please fill in the profile page with the requested informations
- -Activate Bluetooth on your phone or tablet
- Connect to the converter via the application (the converter has a serial number of type CV-03-XXXX)
- When the connection is made, you will see the data (batterie voltage, amps production, converter temperature)
- You can enable the Speed Over Ground display from the mobile GPS chip. (This requieres the Location function)

To realize a datalog, you just have to choose to “store the datas” in the application’s parameters; you can then find your logs in “history” and you can send them by mail easily.

6. SPECIFICATIONS

6.1. POD 600 technical characteristics

- ♦ Hydrogenerator (H-600-03):

Nominal power: 600 W

Nominal voltage: Three-phase, 40 V

Rated current: 9 amp

Weight: 5 kg

- ♦ Converter (CV-03):

Nominal power: 600 W

End of charge voltage: 14.3V / 28.6V

Maintenance voltage: 13.8V / 27.6V

Power limit: 600 W or 40 amp

Solar input: 50 V / 14 amp max

Weight: 1.5 kg

Dim.: 210 x 105 x 60 mm

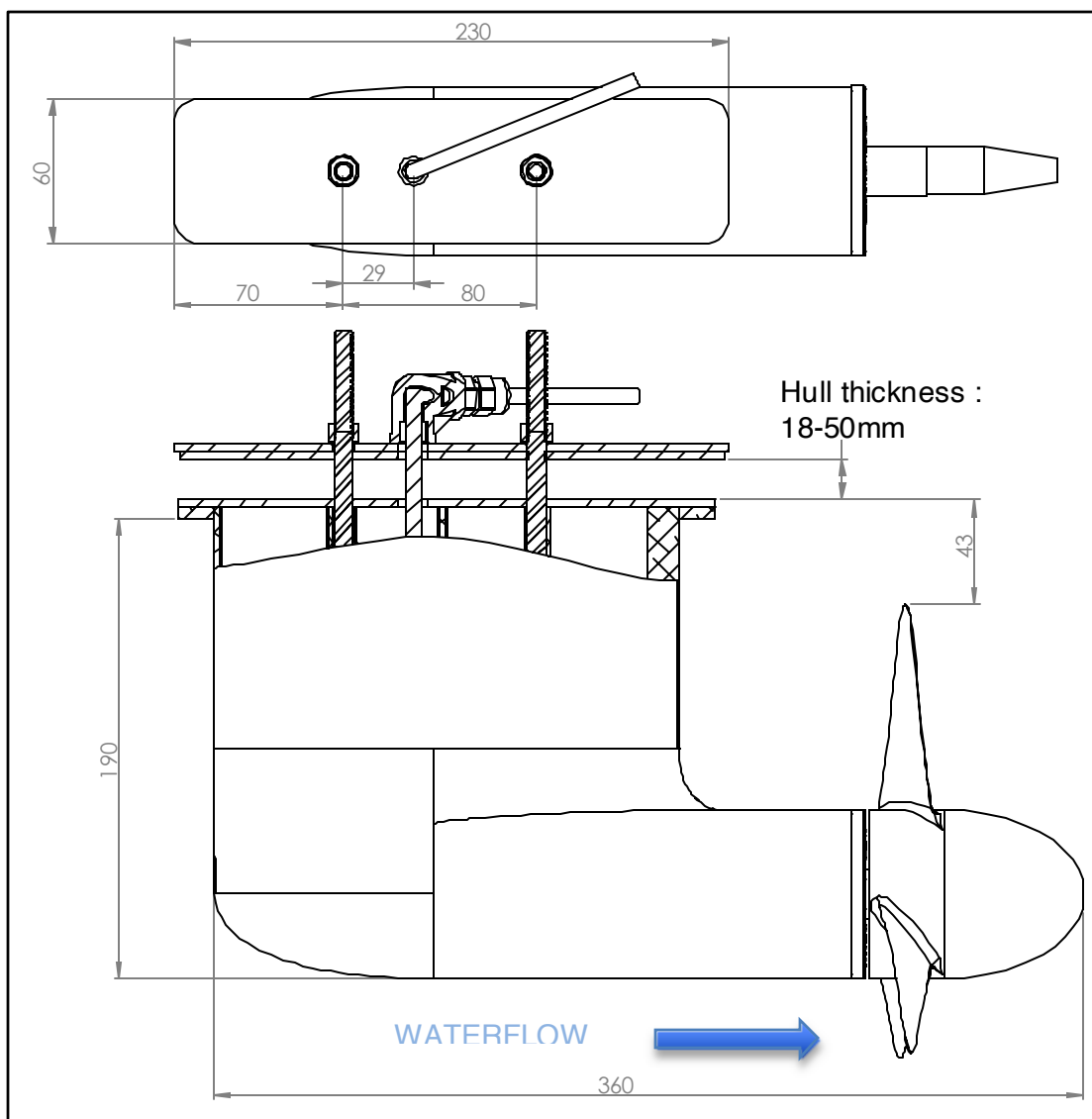

Dimensions of the POD 600 hydrogenerator in mm

6.2. Operating principles

- The hydrogenerator:

The hydrogenerator consists of a permanent magnet alternator producing a very low three-phase current (0-40 V). This alternator technology allows for very high output, but has the disadvantage of generating high voltages during overspeed.

- The ON/OFF function:

The relay connected to a switch (not supplied) allows the hydrogenerator's phases to be short-circuited. This is the best way to safely stop energy production. To repower the device, simply toggle the switch to ON. This relay does not consume any power when in the OFF position and consumes 100 mA when in the ON position. It is important to switch off the load on the hydrogenerator when motoring, otherwise the generator may be damaged.

- Protection against overvoltage:

To prevent the voltage from surging over 40 V, the hydrogenerator is equipped with an electronic system that momentarily short-circuits the alternator during overspeed. This embedded circuit protects the systems located downstream of the alternator.

When the device works over-speed, it produces a specific and audible rumble.

This may happen for one of the following reasons:

1 – A cable has been disconnected or the fuse has blown and the converter is no longer connected to the batteries. The hydrogenerator is freewheeling and is no longer slowed by the electromagnetic force. The converter is possibly turned off.

2 – The three-phase cable has become completely disconnected. In this case, the LEDs flash from red, to orange and then to green, indicating that the battery is connected but that there is no power input.

3 – A three-phase wire has become disconnected. In this case, the converter continues to charge but less efficiently. The LEDs display a constant colour ranging from violet, to blue and then to white which is replaced by 2 red flashes every 5 seconds.

4 – The batteries are charged or the battery capacity is too weak. The converter has finished charging the batteries or the batteries cannot absorb enough energy to prevent the propeller from freewheeling. The converter indicates this status with a green flash every 5 seconds. **In this instance, we recommend switching off the device.**

5 – The boat is sailing faster than the propeller speed range and the converter is running at maximum capacity.

- The converter:

transforms the alternating current coming from the alternator into a continuous current compatible with the batteries. This voltage is regulated at several levels depending on the state of charge of the batteries. During charging, voltage is regulated at 14.3 V / 28.6 V (absorption phase). When conditions allow for fully charging the batteries, the converter regulates to a lower voltage (13.8 V / 27.6 V) to maintain the batteries without damaging them (maintenance/floating phase).

7. MAINTENANCE

Originally designed for ocean racing, the hydrogenerator benefits from the latest technology in terms of resistance and reliability. All metallic parts are made from either specially treated aluminium or A4 stainless steel.

Watertightness is guaranteed using cutting-edge industrial gaskets that have a service life of several thousand hours and can easily support circumnavigation of the globe.

The housing is filled with a lubricating oil to prevent any water seepage.

The hydrogenerator therefore requires no particular maintenance other than cleaning of the external parts:

- Regularly sponge clean the device's housing and propeller to reduce any potential colonisation by micro-organisms.
- The generator and propeller mountings should be regularly inspected to ensure that they are tight.
- The electrical connections should be inspected to ensure that they are tight and corrosion-free.

WATT&SEA recommends servicing every two years or every 10,000 miles. For this, Watt&Sea offers servicing packages tailored to your individual needs. For information visit www.wattandsea.com or contact your distributor.

8. F.A.Q.

8.1. Operation

- What drag is to be expected?

The drag depends on the speed of navigation. At 6 knots, we estimate that the average drag is 10 kg. To calculate the loss of speed for a particular boat, you need to compare the total drag of the hull at 6 knots with 10 kg of drag of the hydrogenerator at the same speed. Our immersion and lifting trials at a constant speed on lifting hydrogenerators have not shown any significant difference on the speedometer.

- What happens when the batteries are charged?

The electronic regulator automatically charges the batteries. When they are fully charged, the propeller freewheels and the noise produced by the hydrogenerator changes (thudding sound). **In this instance, we recommend switching off the device with the supplied relay.**

- Is the hydrogenerator producing a rumbling sound?

This means that the batteries are fully charged. The hydrogenerator starts to freewheel and produces a thudding, almost rumbling sound. **In this instance, we recommend switching off the device with the supplied relay.**

- Is it possible to use the hydrogenerator with the engine?

No, we recommend switching off the device with the supplied relay. Otherwise the converter may interpret that the batteries are full (high current output from the alternator) and put the propeller in freewheel.

- Do the converter's LEDs consume energy?

The converter has a residual consumption as one LED is always lit. It cuts out in the event of low voltage (11.9 V). Consumption ranges from 0.05 to 0.1 amps.

- Ion lithium batteries?

The converter is designed to charge lithium batteries as its voltage is regulated and cannot exceed the maximum value of 14.3 V (or 28.6 V).

It can be programmed with specific voltages through the Watt&Sea application. **Be careful not to exceed the maximum recommended voltages for your batteries, to avoid any risk of damage or fire.**

9. WARRANTY

Coverage and warranty period: Our products are designed for very specific conditions of use. It is the responsibility of our customers to ensure the appropriate use of our products. Our systems are covered by a two-year warranty against any manufacturing defect. The warranty period starts on the date of purchase of our products by the distributor.

The warranty is limited to the standard replacement of a defective part or, if necessary, the entire system, upon receipt of the part in question. Under civil law, it is the responsibility of the purchaser to fulfil the burden of proof regarding the previous nature of the claimed latent defect.

Any returned systems or parts must be accompanied by the warranty returns form (see below), duly completed as follows: name and address of the customer, date of purchase, type of boat, defective parts, description of the structural or design defect, and description of the conditions under which the system was used.

Returned systems or parts shall only be accepted with the prior written consent of WATT&SEA, and must be returned by prepaid delivery. Should the replacement of the WATT&SEA product prove to be due to a defect covered by the warranty, these delivery costs shall be refunded.

Under no circumstances shall returned systems or parts be refunded; they shall only be replaced.

Situations not covered by the warranty:

This warranty shall not apply if the system in question:

- has suffered an accident, or undergone unauthorised alterations or repairs;
- has not been installed by a professional installer in strict compliance with the procedure specified by WATT&SEA in the installation and user manual supplied with the generator;
- has been:
 - o installed or serviced in an inappropriate manner, or used under too high a charge;
 - o subjected to abuse or neglect

The warranty shall not take into account any failures due to simple wear and tear or normal ageing of the structures and materials, any scratches, or any cracks or starrng that may appear following an impact.

Under no circumstances shall WATT&SEA be liable for any special, incidental or consequential damages.

Should you encounter a problem with your WATT&SEA hydrogenerator, please contact your distributor/installer who will help you find a solution.

REGISTER YOUR PRODUCT ONLINE

For traceability under the warranty, please register the product on our website: www.wattandsea.com.

10. FORM FOR REQUESTING AN AFTER-SALES SERVICE RETURN

Owner	
Name:	Phone no.:
Address:	Email:
	Country:
Date of purchase of the hydro generator: Serial no. (see installation manual) - of the hydro generator: - of the converter:	Type of boat:
Conditions of use (frequency / specific conditions having revealed the defect): 	
Defect noticed:	
Date: Signature:	

Distributor / Installer	
Name:	Phone no.:
Address:	Email:
	Country:
Date of purchase of the hydro generator:	Has the defect been confirmed?
Was installation carried out in compliance with the instruction manual?	Installer name and contact details:
Defective sub-assemblies to be replaced:	
Date:	
Signature:	
After-Sales returns authorisation no.:	