

HYDROGENERATOR CRUISING 300 AND CRUISING 600 Installation and instruction manual

Version	V5
Date	03/2022
Contact	contact@wattandsea.com

Congratulations !

You have just purchased the most powerful hydrogenerator of its kind. Inspired by the requirements of ocean racing yachts, designed to take into account the stresses experienced by monohulls, this hydrogenerator will radically change your energy management at sea and become your main source of power while sailing.

This product has been thoroughly inspected. The product comes with the WATT&SEA warranty described in the "Warranty Terms" chapter of this installation guide. For traceability under the warranty, please register the product on our website: www.wattandsea.com

Designed & manufactured in France by:

WATT&SEA SARL
3 rue Jacques Cartier
17000 La Rochelle
France
www.wattandsea.com

TABLE OF CONTENTS

1.	SAFETY PRECAUTIONS	37
1.1.	ELECTRICAL HAZARDS	37
1.2.	INSTALLATION	38
1.3.	OPERATION	38
2.	CONTENTS OF THE HYDROGENERATOR PACK	39
3.	ADDITIONAL EQUIPMENT REQUIRED	40
4.	MECHANICAL INSTALLATION	41
4.1.	ASSEMBLING THE PROPELLER	41
4.2.	POSITIONING THE HYDROGENERATOR ON THE TRANSOM	42
4.3.	INSTALLING THE BRACKET ON THE TRANSOM	44
4.4.	RIGGING THE IMMERSION/LIFTING SYSTEM	45
4.5.	DISMANTLING THE PROPELLER	47
4.6.	MOUNTING THE ELECTRONIC CONVERTER	47
5.	ELECTRICAL INSTALLATION	48
5.1.	THREE-PHASE WIRING OF THE HYDROGENERATOR	48
5.2.	USING A SOLAR PANEL	49
5.3.	CONNECTING THE CONVERTER TO THE BATTERIES	50
5.4.	INTERPRETATION OF THE CONVERTER'S LEDs	52
5.5.	USING BLUETOOTH	53
6.	INSTALLATION SUMMARY	54
7.	SPECIFICATIONS	55
7.1.	TECHNICAL SPECIFICATIONS OF THE 970 MM AND 610 MM CRUISING 600	55
7.2.	TECHNICAL SPECIFICATIONS OF THE 970 MM AND 610 MM CRUISING 300	56
7.3.	OPERATING PRINCIPLES	57
7.4.	PERFORMANCE	58
8.	MAINTENANCE	60
9.	LIST OF SPARES	61
10.	F.A.Q	62
11.	WARRANTY	64
12.	FORM FOR REQUESTING AN AFTER-SALES SERVICE RETURN	65

1. SAFETY PRECAUTIONS

While our primary concern in designing the hydrogenerator was your safety, certain precautions must nevertheless be taken when operating any mechanical or electrical equipment.

Please keep the following safety factors in mind when installing and operating the hydrogenerator, and be aware at all times of the electrical and mechanical hazards inherent in operating the propeller.

MECHANICAL HAZARDS

The hydrogenerator's blades are made of a composite material and can rotate at a speed of over 100 kph (62 mph).

At this speed, the blades are practically invisible and can cause serious injuries.

WARNING : WHEN INSTALLING THE HYDROGENERATOR, MAKE SURE THAT THE PROPELLER IS SAFELY POSITIONED OUT OF REACH. DO NOT ATTEMPT TO STOP THE PROPELLER WITH YOUR HAND WHILE THE GENERATOR IS RUNNING.

1.1. *Electrical hazards*

Heat in wiring systems often results from undersized cables or faulty connections.

Batteries have a very high current carrying capacity. A short-circuit in their cables may result in an outbreak of fire. To prevent this hazard, you must install a 50 amp fuse between the converter and each battery.

If the fuse is defective, you must determine the reason before resetting or replacing it.

WARNING : YOU MUST INSTALL AN EXTERNAL 50 AMP FUSE.

WARNING : ALWAYS PLACE THE HYDROGENERATOR IN THE LIFTED POSITION BEFORE STARTING WORK ON IT.

1.2. *Installation*

Please observe the following precautions during installation :

- Remove the hydrogenerator from the water.
- Keep safety in mind at all times ! Have someone help you throughout the duration of the installation.
- Remember : the batteries should be connected last.

1.3. *Operation*

- Check the support structure, blades and electric circuits on a regular basis.
- Although the propeller blades are made of very strong materials, they may warp or break if they come into contact with a submerged object, acting as a fuse.

WARNING : NEVER TOUCH THE PROPELLER WHEN IT IS SPINNING.

WARNING : NEVER USE THE HYDROGENERATOR TO STEP ONTO OR OFF THE BOAT AS THIS MAY WARP THE DRIVE SHAFT.

WARNING : WHEN RUNNING, THE CONVERTER CAN REACH VERY HIGH TEMPERATURES.

2. CONTENTS OF THE HYDROGENERATOR PACK

Check the contents of your pack against the list below :

- 1 HYDROGENERATOR with 5 metres of cable (H-300-03 or H-600-03)
- 1 LIFTING BRACKET (K-03)
- 1 THREE-BLADE (P-240-03)
- 1 PROPELLER EXTRACTION KIT (EP-03)
- 1 CONVERTOR (CV-03) with its bag of connectors :
 - 1 hydrogenerator connector
 - 1 solar connector
 - 3 battery connectors (2 positive, 1 negative)
- 1 LOW FRICTION RING (AN-03)
- 1 LOCKING PIN (PI-03)
- 1 FASTENING KIT (F-03)
- 1 INSTRUCTION MANUAL



The package and its contents

3. ADDITIONAL EQUIPMENT REQUIRED

- Three-phase cable, minimum $3 \times 1.5 \text{ mm}^2$, for connecting the hydrogenerator to the converter (if length $< 10\text{m}$; if length $>10\text{m}$ please use $2,5\text{mm}^2$).
- Red and black 10 mm^2 cable for connecting the batteries.
- Battery terminals for the 10 mm^2 battery cable.
- 50 Amp fuse or thermal circuit breaker (for example : Series 187 from Blue Sea Systems)
- Junction box or waterproof connectors for three-phase cables. WATT&SEA offers an optional connection kit with cable and waterproof power socket (Ref: PL-04).
- Bolts for fixing the bracket's stainless steel fork mountings to the hull.
- Lifting/lowering line (6:1 or 4:1 hoist, depending on boat sailing speed) with a 6 mm diameter covered line (Refs: PA-04 and PA-04-HS).
- Install phonic insulation between the transom and the mounting bracket to minimize vibrations (rubber sole thickness 2 to 4mm)

THE QUALITY OF THE POWER SOCKET IS PARAMOUNT : PREFERABLY CHOOSE A PLASTIC MODEL QUALIFIED FOR 50 VCC - 12 AMP.

DO NOT USE METAL POWER SOCKETS WITH BRASS CONTACTS AS THESE CORRODE TOO QUICKLY.

4. MECHANICAL INSTALLATION

Your hydrogenerator is shipped partially disassembled. Please read the instruction manual carefully before starting installation.

4.1. *Assembling the propeller*

- Slide the propeller onto the shaft.
- Check that the stainless steel washer (3) has been pre-mounted at the end of the propeller. If not, insert it.
- Insert the HSHC M5x20 screw (4)
- Hold the propeller with one hand and tighten the screw using the 4 mm (5/32") Allen key until the screw starts turning the propeller.

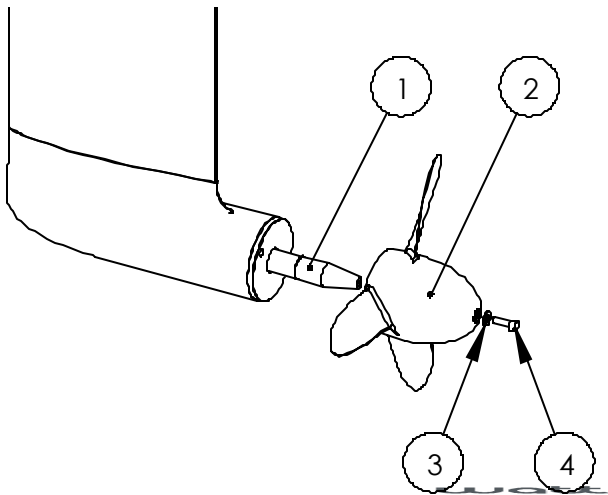

N	Designation
1	Shaft
2	Three-blade propeller
3	Stainless steel washer
4	M5x20HSHC screw

Exploded view of the shaft, propeller, washer and M5 screw

4.2. ***Positioning the hydrogenerator on the transom***

Correctly positioning the hydrogenerator is crucial for optimizing its performance.

The following criteria must be respected during the installation :

- **Immersion depth :**

The hydrogenerator is supplied with a submerged aluminium leg measuring 610 mm (24 in) or 970 mm (38 in). The recommended depth between the surface and the propeller axis is 300 mm (12 in). The greater the depth, the farther the propeller will be from the wake of the hull, and the better the performance of the hydrogenerator. However, the most important the lever arm is, the greater the force on the mountings and during lifting will be.

We recommend a length of 970 mm (38 in) as a satisfactory compromise for most monohull installations.

The 610 mm leg is suitable for very large monohulls with a device installed on each side.

- **Flow quality :**

The quality of water flow is a key element for obtaining satisfactory power output.

N.B. : Do not position the hydrogenerator directly in the wake of an appendage or too close to a saildrive.

Wherever possible, position the hydrogenerator several inches to the side, in order to offset it from the rudder, the propeller or other appendix.

Example of installation with the longer leg (970 mm / 38 in) :

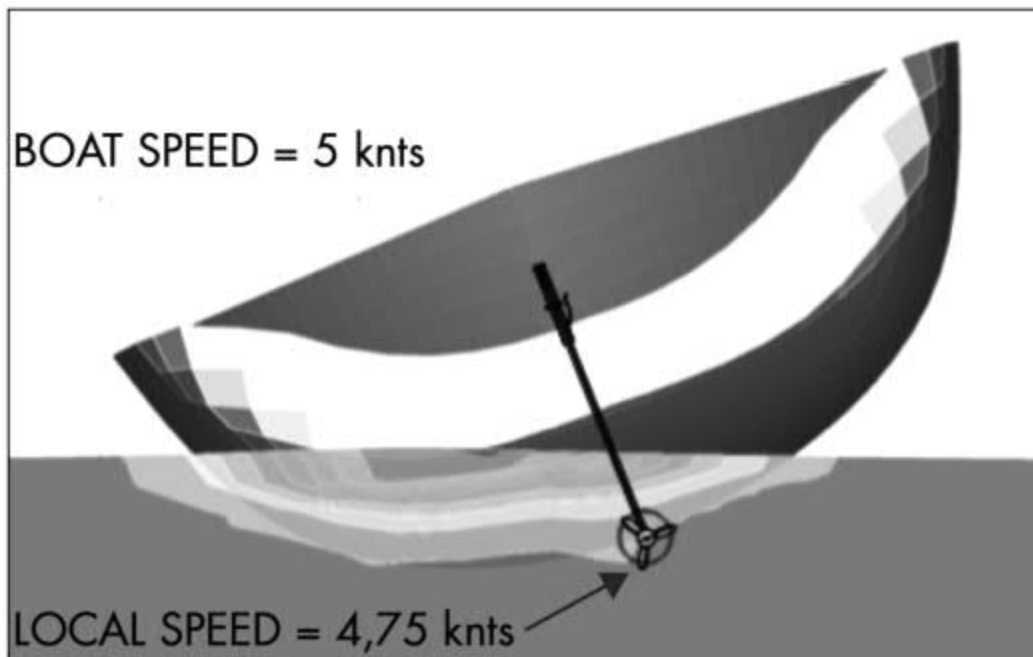

Installation on a 10 m (33 ft) Figaro II heeling at 20° (CFD by CRAIN)

The length of 970 mm is enough for it to be immersed properly during listing because the loss of speed due to the wake is about 5%.

- **Examples of installations with the shorter leg (610 mm / 24 in) :**

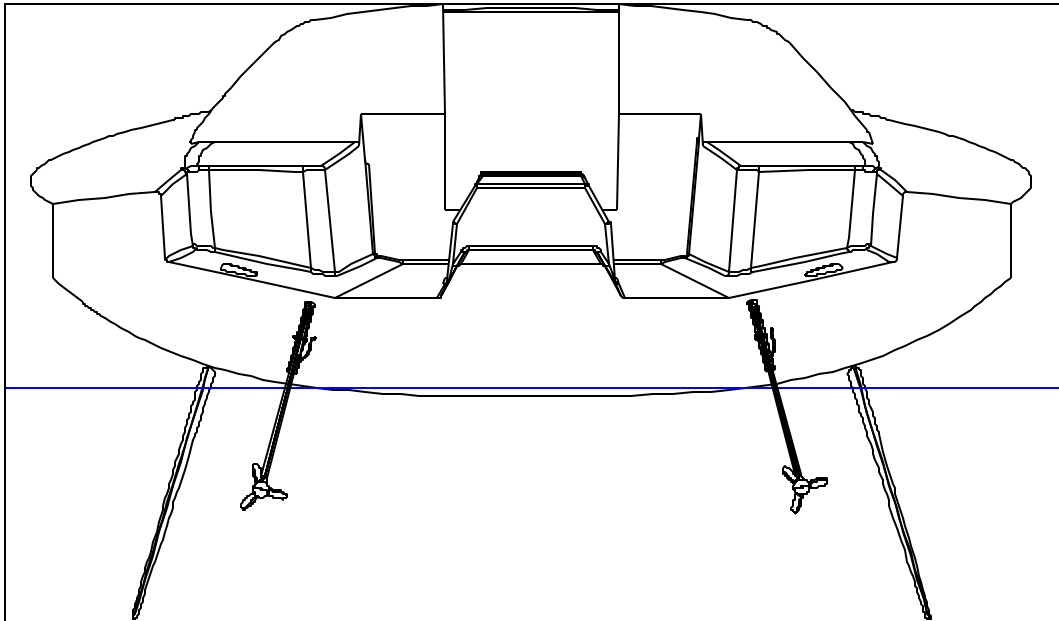

Dual installation on a Pogo40 (© CN STRUCTURES)

The hydrogenerators are placed parallel to the rudders but approximately 30 cm (12 in) to the inside to avoid their wakes.

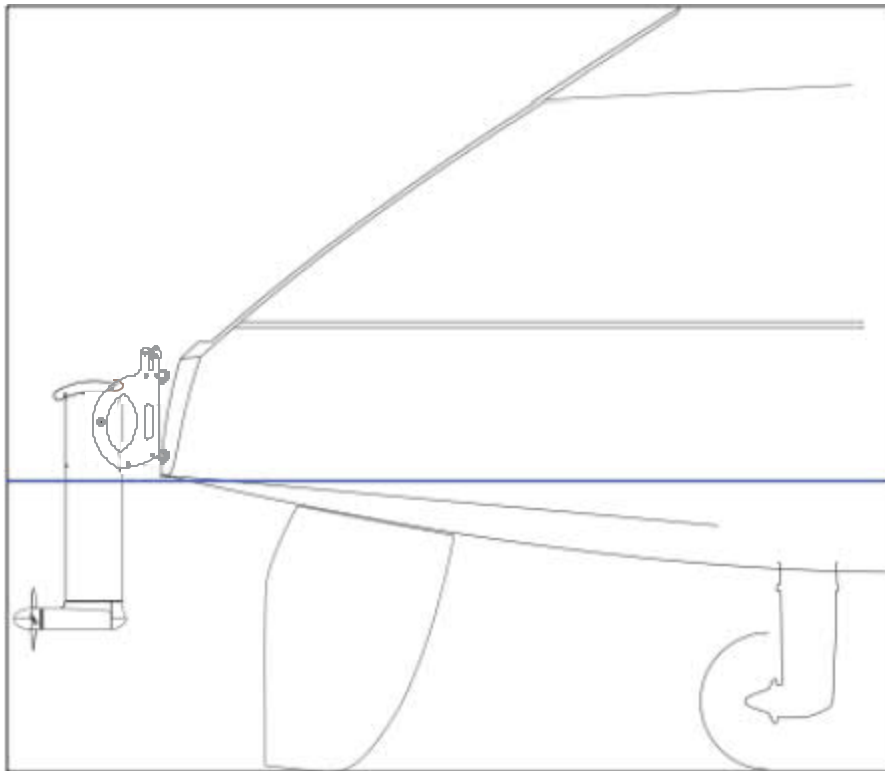

Installation on a catamaran (© OUTREMER YACHTING)

Here, the hydrogenerator is positioned to the side, out of the wake of the nearby rudder.

4.3. *Installing the bracket on the transom*

Depending on your boat's transom, its structure might need to be reinforced to take the stress on the mountings. Phonic insulation also reduces vibrations.

WARNING : Due to the size of the lever arm, the maximum theoretical stress on the bracket's fork mountings is estimated at around 300 kg. Your mounting system should be adapted accordingly.

The bracket must be adapted to the 8 mm diameter fork mountings that are securely mounted onto the transom.

These fork mountings must be mounted in such a way as to compensate for any tilt of the transom. The diagram below will help you to adapt the mountings to your boat.

N.B. : The leg must be vertical in the lowered position, leading edge abutting lower gudgeon.

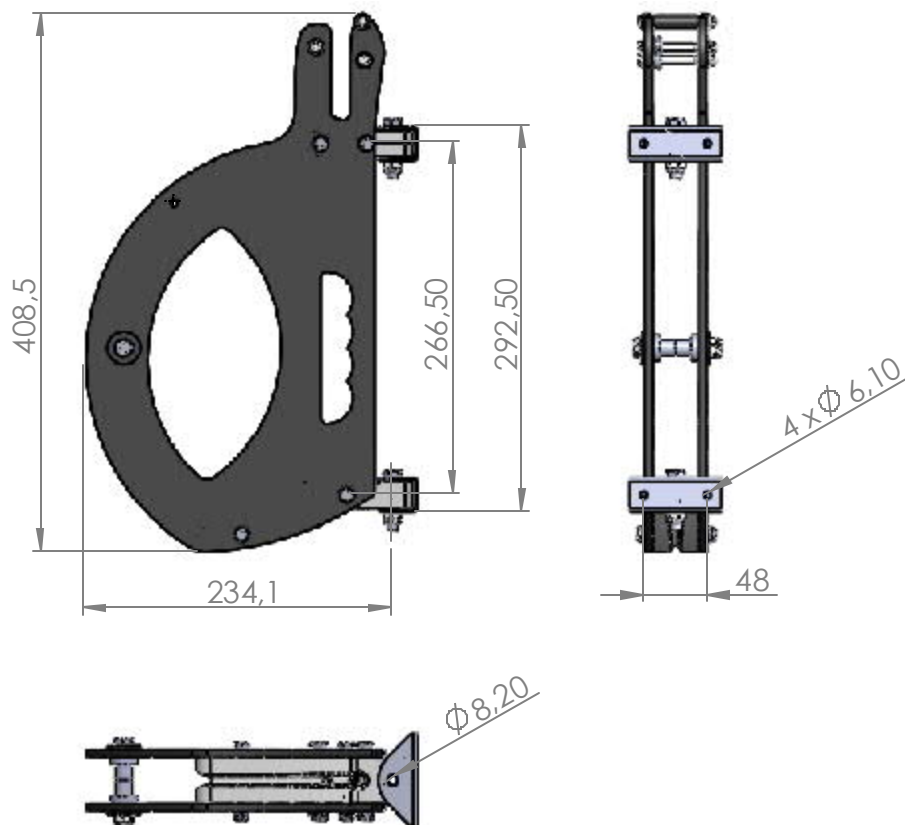

Lifting Bracket dimensions

4.4. *Rigging the immersion/lifting system*

The hydrogenerator is supplied with a lifting bracket that functions in a similar way to the systems used on the rudders. It facilitates access to the propeller when the device is lifted, for the removal of seaweed for example.

The lowering and lifting procedures are carried out using a hoist which is not included in the pack. The maximum traction during lifting is around 40 kg. It is therefore recommended to rig a 4:1 to 6:1 hoist with a 6 mm diameter sheathed line (hoist available in option at Watt&Sea, refs: PA-04 and PA-04-HS, depending on boat sailing speed).

- Assembly of the lowering rope (as per blue line below):

Pass the rope successively :

- in the cam-cleat of the bracket
- in the two gudgeons of the bracket
- through the low friction ring
- in the hole of the lower gudgeon
- Finish the assembly by an eight-knot (see picture below)

- Assembly of the lifting rope ; please see in green below



•
Assembly of the lowering line using a low friction ring

The cleat integrated into the bracket is used to lock the lowering and lifting line. For permanent blocking in lower position, you can use the locking pin.

Please take care in pull in a vertical way on the immersion and lifting lines to avoid the cleat from opening unexpectedly.

N.B. : When the hydrogenerator is submerged, the leg should sit flush in the groove of the gudgeon provided for this purpose. If this is not the case, the lateral support will be less efficient, and this may result in mechanical damage.

It is also advisable to hold the lifting end in place using an elastic cord to prevent it from leaving the groove.



Lifting the hydrogenerator

4.5. *Dismantling the propeller*

To dismantle the propeller, you should use the M6 extractor screw (supplied with the hydrogenerator.)

- Unscrew the M5 screw that holds the propeller at the end of the shaft.
- In its place, insert the M6 screw and tighten it using the appropriate key. This will have the effect of effortlessly removing the propeller from its conical fitting.

N.B. : Any method for dismantling the propeller other than the one described above may result in damage to the hydrogenerator.

4.6. *Mounting the electronic converter*

The electronic converter is a box which is resistant to splashes and passive ventilation, guaranteeing long-term protection even in humid environments.

The converter must nevertheless be installed inside the boat, preferably in the mechanical room in close proximity to the batteries.

WARNING : WHEN RUNNING, THE CONVERTER CAN REACH VERY HIGH TEMPERATURES. AS SUCH, ASSEMBLY SHOULD BE CARRIED OUT IN A VENTILATED SPACE.

**N.B. : To ensure proper ventilation, the converter must be mounted on a vertical bulkhead, with the ventilation grids in a vertical position.
If you wish to get an access to the converter's status, keep in mind to get a visual access to the LEDs located on the top (white cover)**



As it is so light, the converter can be securely attached using the Velcro provided.

- degrease the surface on which the converter will be installed
- remove the protective tabs of the strips of Velcro provided on the converter
- apply the quick-drying glue if the surface is very uneven (against plywood, fibreglass ...)
- firmly attach the converter to the surface

5. ELECTRICAL INSTALLATION

Recommendations for electrical connections :

Please consult local/national safety rules before installation.

All electric cables must be carefully insulated. For maximum protection, cover the cables with electrical cable sheaths.

WARNING : CONNECTIONS MUST BE INSPECTED REGULARLY TO DETECT SIGNS OF CORROSION AND CLEANED WHEN NECESSARY. DAMAGED OR CORRODED CONNECTIONS LEAD TO A SIGNIFICANT DROP IN PRODUCTION.

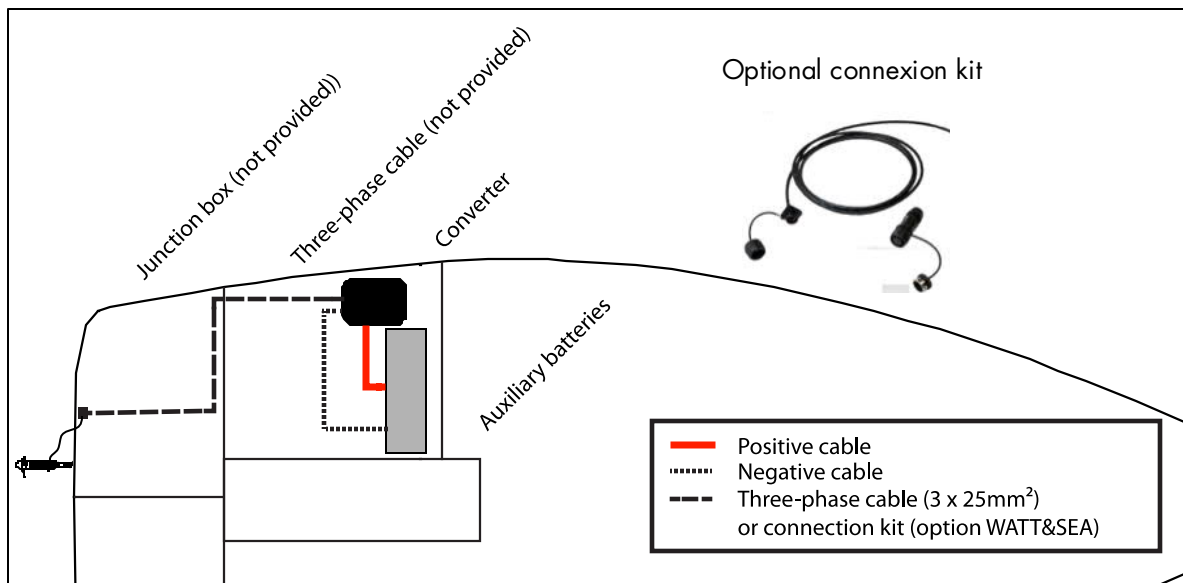

Wiring principle

5.1. *Three-phase wiring of the hydrogenerator*

WARNING : ALWAYS PLACE THE HYDROGENERATOR IN THE LIFTED POSITION BEFORE STARTING WORK ON IT.

The hydrogenerator is fitted with a small diameter electrical cable of sufficient length to pass through the transom. This is a three-phase cable.

- We recommend using the connection kit with a cable and waterproof power socket. (Ref. PL-04).
- From here, use a three-phase cable to connect the hydrogenerator to the converter. If the length of this cable is less than 10 metres, use a 3 x 1.5 mm² section. Above 10 metres, use a 3 x 2.5 mm² section.
- The converter is connected using the connector kit provided. Connect the 3 phases on one of the premounted plugs supplied (Ref. CA-03). There is no importance in the connection arrangement of the 3 other wires (BROWN, ORANGE, RED). The black wire must not be connected, it is used to wire a solar panel (please see below). You can connect them with for example WAGO 222 connectors. See the assembly instructions below.

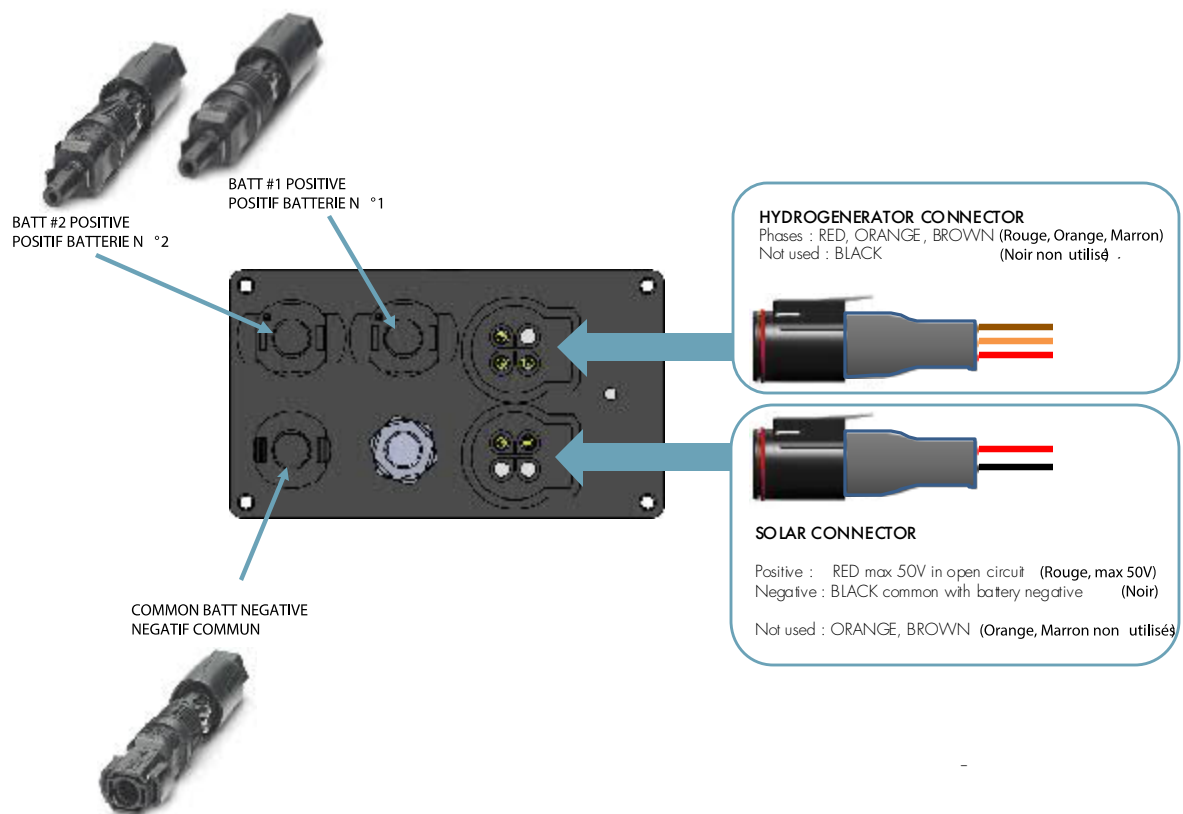

Converter's connections

N.B. : Using a cable that is less than 3 x 1.5 mm² in diameter will affect both the output and the performance of the hydrogenerator. The GND position must not be connected (ground terminal).

N.B. : The phase sequence is irrelevant. Therefore, there is no need to take into account the color or numbering of the cables.

5.2. *Using a solar panel*

The converter has 2 inputs : one for the hydrogenerator and one for the solar panel. The solar panel's maximum voltage must not exceed 50 VCC and the intensity must not exceed 14 amps. Minimum voltage to start producing with the solar panels is 7,5VCC.

Wire the solar panel using the 2nd premounted plug CA-03, taking care of the polarity:
 NEGATIVE SOLAR: BLACK
 POSITIVE SOLAR: RED

WARNING : RESPECT THE POLARITY OF THE SOLAR PANEL

When the hydrogenerator and the solar panel generate power at the same time, priority is given to the hydrogenerator. As soon as this is no longer generating power (lifted, the boat is moored) the converter automatically takes into account the solar panel's charge.

5.3. *Connecting the converter to the batteries*

The converter must be placed as close as possible to the batteries in order to minimize losses due to cable length. The maximum recommended distance is 2 metres.

The batteries are connected to the converter via a solar connector supplied.

The converter has an internal 2 output isolator that makes it possible to charge two battery units separately. The 2 battery banks must be at the same voltage.

WARNING : RISK OF OVERLOADING AND FIRE. THE TWO BATTERY BANKS MUST BE THE SAME TYPE AND HAVE THE SAME VOLTAGE.

WARNING : EACH BATTERY BANK MUST BE PROTECTED WITH A 50 AMP FUSE.

We recommend connecting the hydrogenerator's converter directly to the service battery bank. The converter will monitor the batteries independently of the other on-board units, and will charge them when required.

N.B. : Proper operation on one external battery isolator is not guaranteed and may require additional adjustment. Please contact your distributor.

WARNING : NEVER REVERSE THE POLARITY OF THE CONVERTER. THIS WILL LEAD TO THE DESTRUCTION OF THE DEVICE.

Please see on next page to properly dismantle the solar connectors from the converter.

English

SUNCLIX photovoltaic I/O connector for installation in photovoltaic systems for 6 ... 16 mm² solar cables, type PV1-F

1 Safety notes



WARNING: The SUNCLIX plug-in connectors may be connected only by trained electricians.



WARNING: Never plug in or disconnect the SUNCLIX plug-in connectors under load.



NOTE: Use these plug-in connectors only in combination with a 6 ... 16 mm² solar cable, type PV1-F. A safe, electrical connection is only possible with this cable. When laying out the cable, observe the bending radiuses that the manufacturer specifies.



NOTE: Connect this plug-in connector only with other SUNCLIX photovoltaic plug-in connector. When making the connections, be sure to observe the specifications on nominal voltage and nominal current. The smallest common value is permissible.



NOTE: Protect the plug-in connectors from humidity and dirt.

- Do not immerse the plug-in connector in water.
- Never lay out the plug directly on the roofing.
- Attach a protective cap (e.g. PV-C PROTECTION CAP, order number 1785430) to plug-in connectors that are not plugged in.

2 Connecting connectors

You need a slot screwdriver with a 3-mm wide blade (e.g. SZF 1-0.6X3.5; item no. 1204517).

2.1 Connecting the cable (Fig. ①)

- Strip the cable by 18 mm with a suitable tool. Make sure that no individual wires are cut off.
- 1 Carefully insert the stripped wire all the way in. The litz wire ends have to be visible in the spring.
 - 2 Close the spring. Make sure that the spring is snapped in.
 - 3 Push the insert into the sleeve.
 - 4 Tighten the cable gland to 3 Nm.

2.2 Assemble the connector

- Bring the plug and the socket together. The connection snaps close thereby.
- Pull on the coupling to check the proper connection.

3 Separating the connector (Fig. ②)

- 1 Insert the screwdriver as shown in Fig. ②.
- 2 Leave screwdriver inserted and disconnect the plug and the socket from each other.

3.1 Loosen the cable (Fig. ③)

- 1 Screw open the cable gland.
- 2 Insert the screwdriver at the position shown in Fig. ③.
- 3 Pry the connection open and pull the sleeve and the insert apart.
- 4 Open the spring with the screwdriver.
- 5 Remove the cable.

4 Technical data

Ambient temperature: -40 °C ... +90 °C

Nominal voltage: max. 1500 V DC

Nominal current: 40 A (6 mm²), 50 A (10 mm²), 65 A (16 mm²)

Cable diameter: 5,5 ... 10 [mm]

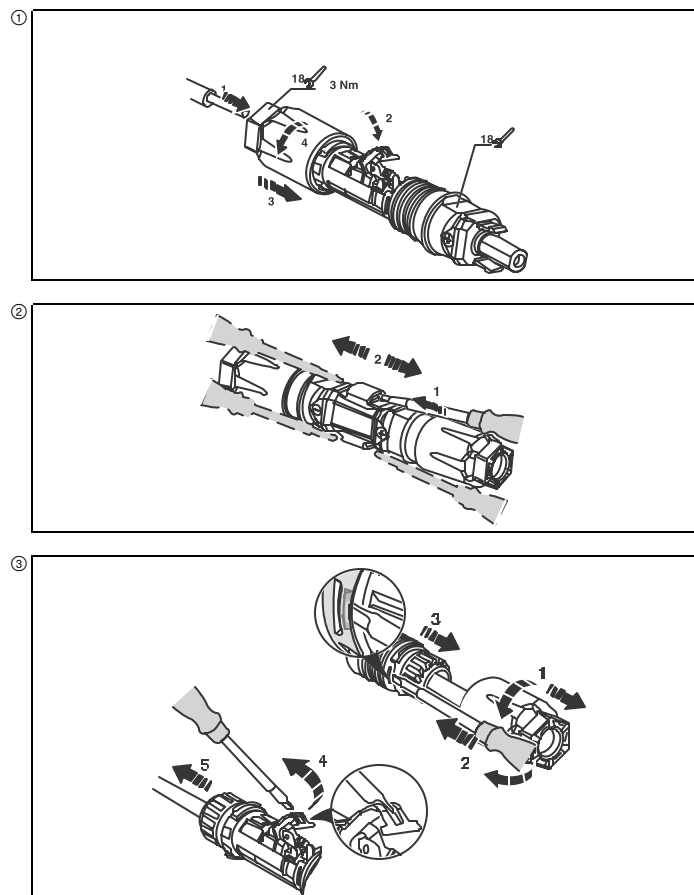

5.4. Interpretation of the converter's LEDs

- When the converter **is not charging**, the battery voltage is indicated by a **pulse** of color which changes from green (12.8 V) to red (11.5 V).
- When the converter **is charging**, the output power is indicated by a **constant color** which changes from violet to blue (120W), to light blue (240W) and finally to white (480W).
- Green or red colored **flashes** may **overlay** the display of the constant color to indicate statuses or anomalies :

SITUATION	VISUAL	COMMENTS
Absorption voltage reached	1 brief green flash every 5 seconds	The battery is full (absorption voltage = 14.3V/28.6V) Please lift up the hydrogenerator
Floating voltage maintained	1 long green flash every 5 seconds	The battery is kept at 100% (floating voltage = 13.8V/27.6V)
Overheating	1 red flash every 5 seconds	The maximum box temperature has been reached
Generator anomaly	2 red flashes every 5 seconds	The hydrogenerator's connection is defective
Overvoltage at input	3 red flashes every 5 seconds	The solar panel or the hydrogenerator are applying a voltage that is too high
Another anomaly	4 red flashes every 5 seconds	Contact your distributor

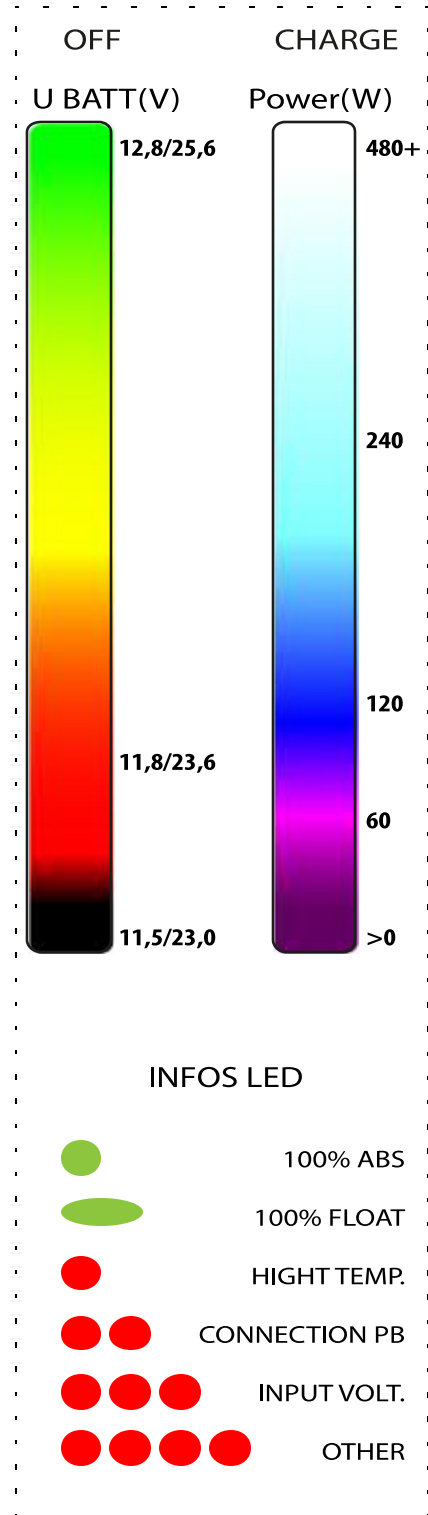

5.5. *Using Bluetooth*

Since the end of 2019, Watt&Sea converters embed a Bluetooth chip (serial numbers above CV-03-1630).

The Watt&Sea application is available on Appstore and Google Play. It will allow you to track your hydrogenerator's production, make data records, and adjust charging settings.

To install and use the application:

- Download the application on Appstore or Google Play
- Please fill in the profile page with the requested informations
- -Activate Bluetooth on your phone or tablet
- Connect to the converter via the application (the converter has a serial number of type CV-03-XXXX)
- When the connection is made, you will see the data (batterie voltage, amps production, converter temperature)
- You can enable the Speed Over Ground display from the mobile GPS chip. (This requieres the Location function)

To realize a datalog, you just have to choose to "store the datas" in the application's parameters; you can then find your logs in "history" and you can send them by mail easily.

6. INSTALLATION SUMMARY

The following instructions set out the main steps in the hydrogenerator installation procedure. This is only a summary. Please refer to the appropriate sections of this manual for detailed instructions.

1. Place the propeller onto the device. (See 4.1)
2. Mechanically mount the hydrogenerator onto the transom. (See 4.2)
3. Install a WATT&SEA connector kit with cable and waterproof power socket (Ref. PL-04).
4. Then, mechanically mount the converter onto a vertical bulkhead, as close as possible to the batteries. (See 4.6)

Make sure that the propeller is not submerged and that it is not possible for the alternator to run during installation.

5. Run the converter's power cables through to the batteries. (See 5.3)

DO NOT CONNECT the cables to the batteries before installation is complete.

6. Attach the battery connectors, then connect the power cables to the batteries : red wire to the positive terminal, black wire to the negative terminal. (See 5.3)
7. Once the converter is connected to the batteries, the LED will come on indicating the current battery power, from red to green. When the propeller starts turning, the color of the LED will change from violet (10W) to blue (120W) and finally to white (>300W)

7. SPECIFICATIONS

7.1. *Technical specifications of the 970 mm and 610 mm CRUISING 600*

- ♦ Hydrogenerator (H-600-03) :

Nominal power: 600 W

Nominal voltage: Three-phase, 40 V

Rated current: 9 A

Weight: 8.2 kg / 7.4 kg

- ♦ Converter (CV-03):

Nominal power: 600 W

Absorption voltage: 14.3 V / 28.6 V

Floating voltage: 13.8 V / 27.6 V

Rated current: 44 A / 22 A

Solar input: 50 V (mini 7,5V) / 14 A max

Weight: 1.5 kg

Dim.: 210 x 105 x 60 mm

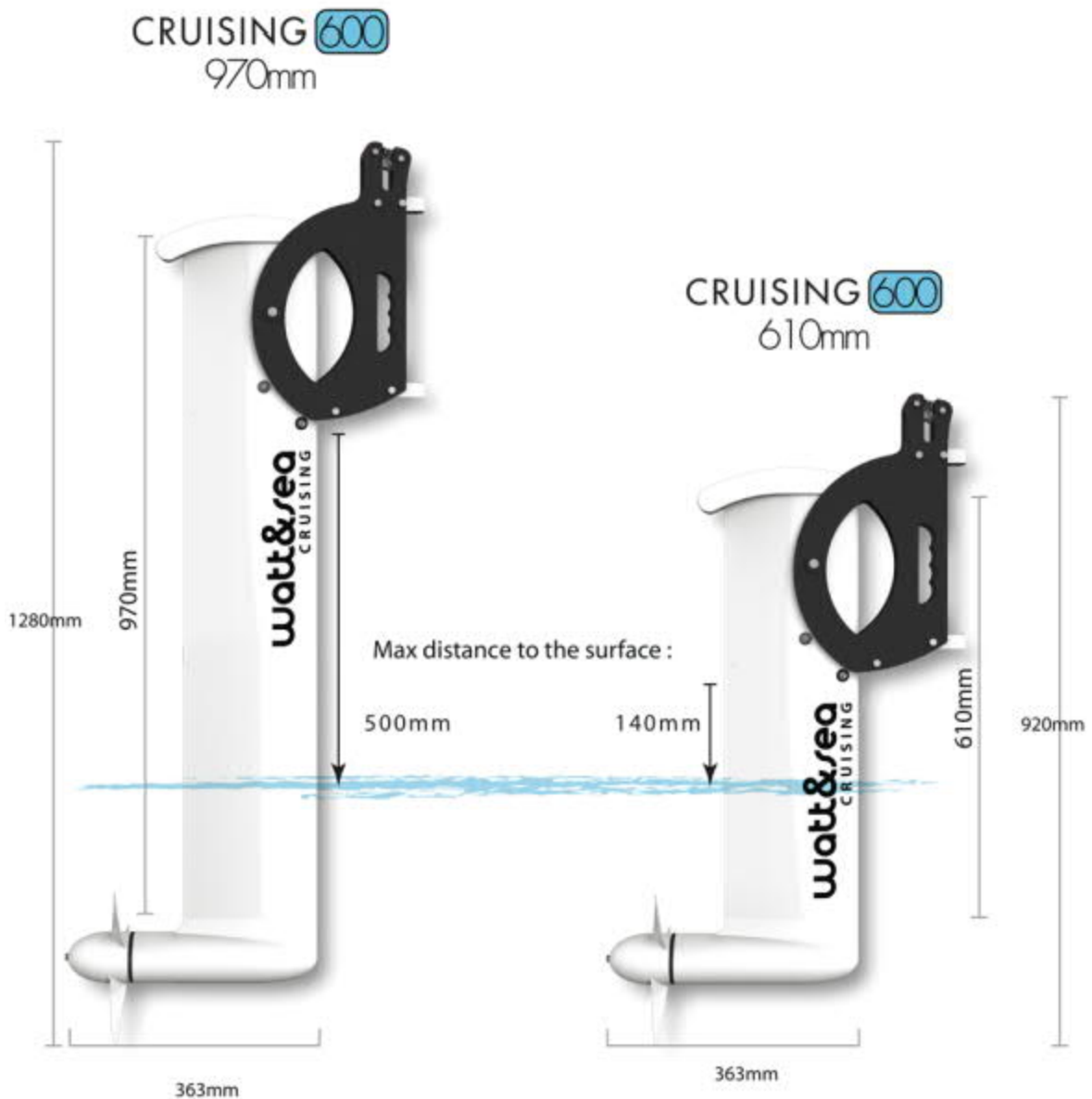

Dimensions of the CRUISING 600 hydrogenerator

7.2. *Technical specifications of the 970 mm and 610 mm CRUISING 300*

- ♦ Hydrogenerator (H-300-03):

Nominal power: 300 W

Nominal voltage: Three-phase, 40 V

Rated current: 9 A

Weight: 7.1 kg / 6.3 kg

- ♦ Converter (CV-03):

Nominal power: 600 W

Absorption voltage: 14.3 V / 28.6 V

Floating voltage: 13.8 V / 27.6 V

Rated current: 44 A / 22 A

Solar input: 50 V (mini 7,5V) / 14 A max

Weight: 1.5 kg

Dim.: 210 x 105 x 60 mm

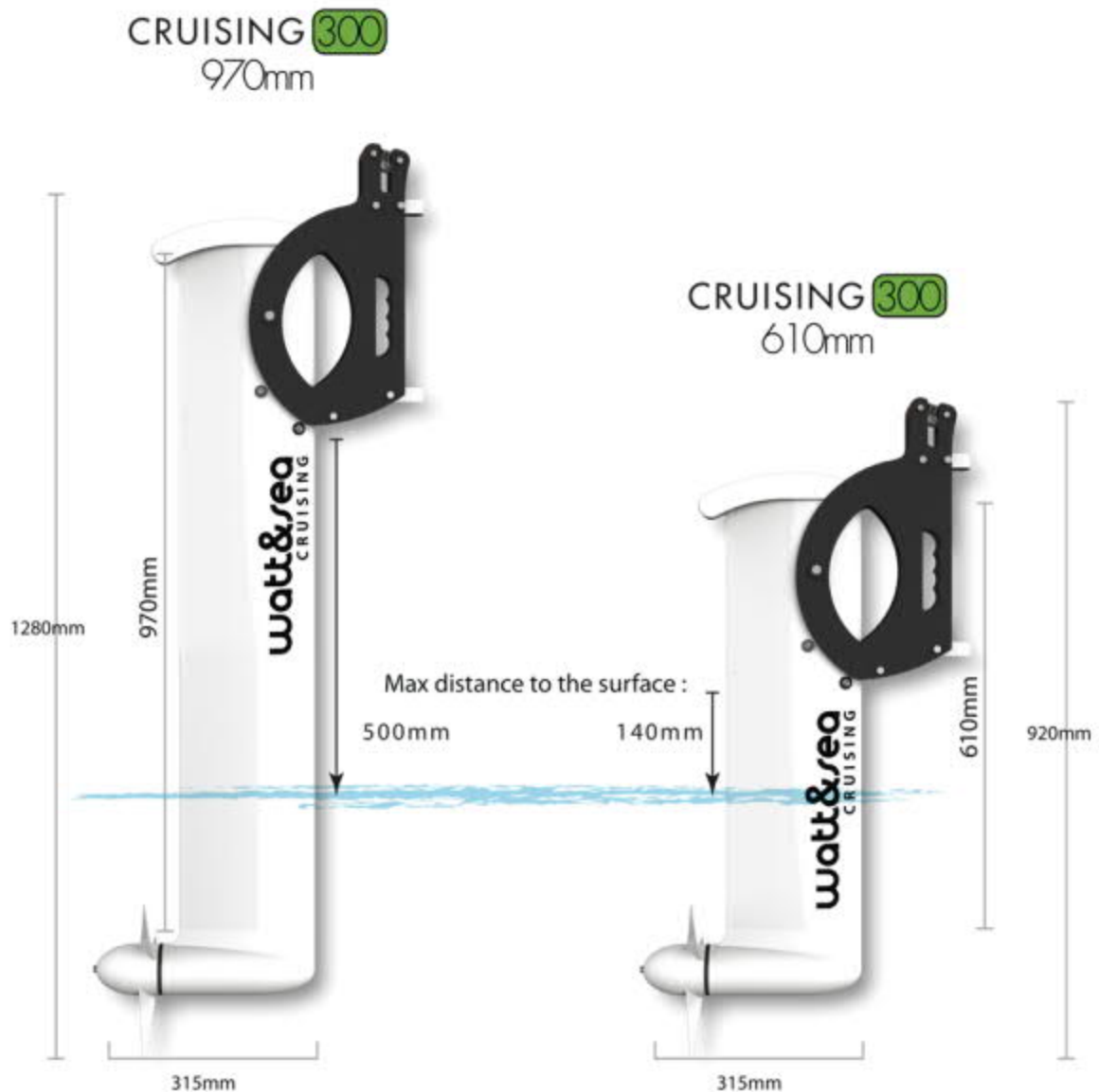

Dimensions of the CRUISING 300 hydrogenerator

7.3. *Operating principles*

- The hydrogenerator :

The hydrogenerator consists of a permanent magnet alternator producing a very low three-phase current (0-40 V). This alternator technology allows for very high output, but has the disadvantage of generating high voltages during overspeed.

- Protection against overvoltage :

To prevent the voltage from surging over 40V, the hydrogenerator is equipped with an electronic system that momentarily short-circuits the alternator during overspeed. This embedded circuit protects the systems located downstream of the alternator.

When the hydrogenerator is working overspeed, it produces a very distinctive and audible rumble. If the hydrogenerator is used for a long time in this situation, the overvoltage protection could be damaged, and is not easily repairable as it is casted in the resin inside the generator.

This may happen for one of the following reasons :

1 – A cable has been disconnected or the fuse has blown and the converter is no longer connected to the batteries. The hydrogenerator is freewheeling and is no longer slowed by the electromagnetic force. The converter is possibly turned off.

2 – The three-phase cable has become completely disconnected. In this case, the LEDs flash from red, to orange and then to green, indicating that the battery is connected but that there is no power input.

3 – A three-phase wire has become disconnected. In this case, the converter continues to charge but less efficiently. The LEDs must display a constant color ranging from violet, to blue and then to white, on which are superimposed 2 red flashes every 5 seconds.

4 – The batteries are charged or the battery capacity is too weak. The converter has finished charging the batteries or the batteries cannot absorb enough energy to slow down the propeller. The converter indicates this status with a green flash every 5 seconds.

5 – The boat is sailing faster than the propeller speed range and the converter is running at maximum capacity.

- The converter :

It transforms the alternating current coming from the alternator into a continuous current compatible with the batteries. This voltage is regulated at several levels depending on the state of charge of the batteries. During charging, voltage is regulated at 14.3V / 28.6V (absorption phase). When conditions allow for fully charging the batteries, the converter regulates to a lower voltage (13.8V / 27.6V) to maintain the batteries without damaging them (floating phase).

7.4. **Performance**

As detailed in section 4.2 concerning the installation of the hydrogenerator onto the transom, performance very much depends on position and the quality of water flow.

The charts given below for the 600 and 300 models correspond with the measurements carried out on a motorboat with 200 mm, 240 mm and 280 mm propellers and a calibrated speedometer.

Propeller diameter	Speed range
280 mm	3 to 9 knots
240 mm	4 to 11 knots
200 mm	6 to 13 knots
200mm PVM	6 to 30 knots

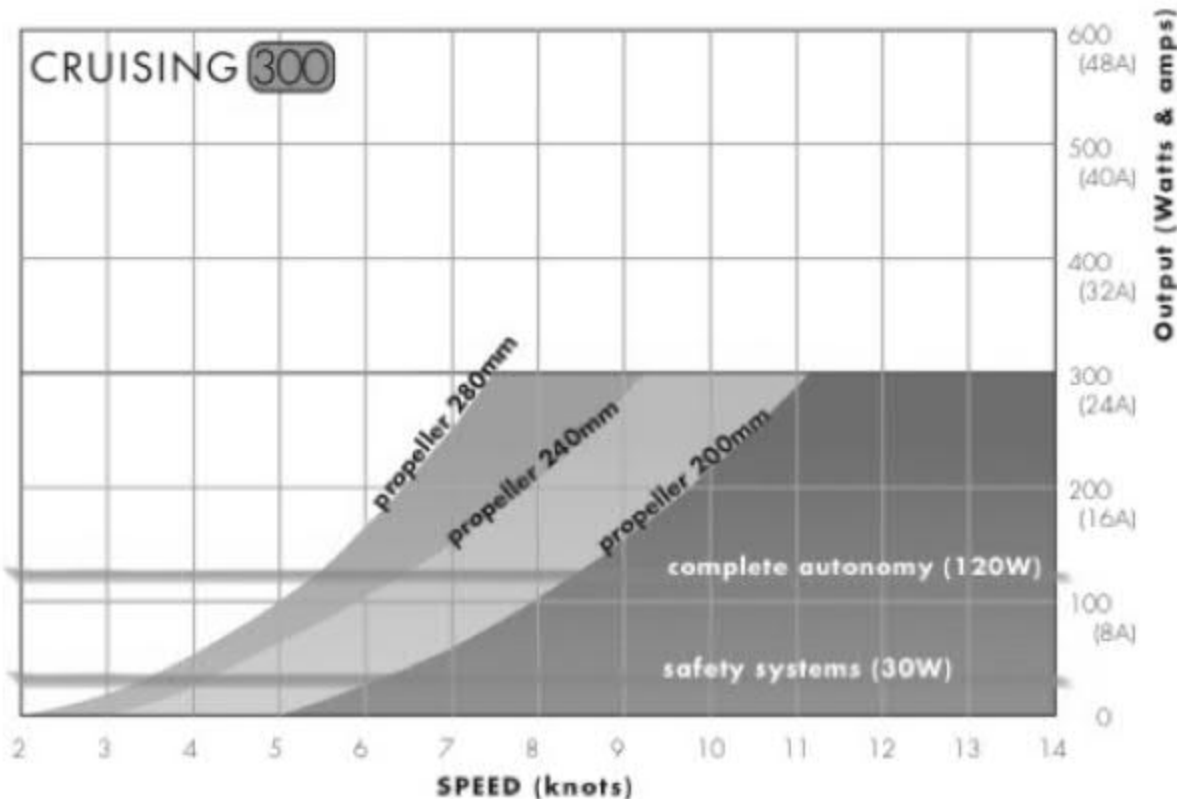
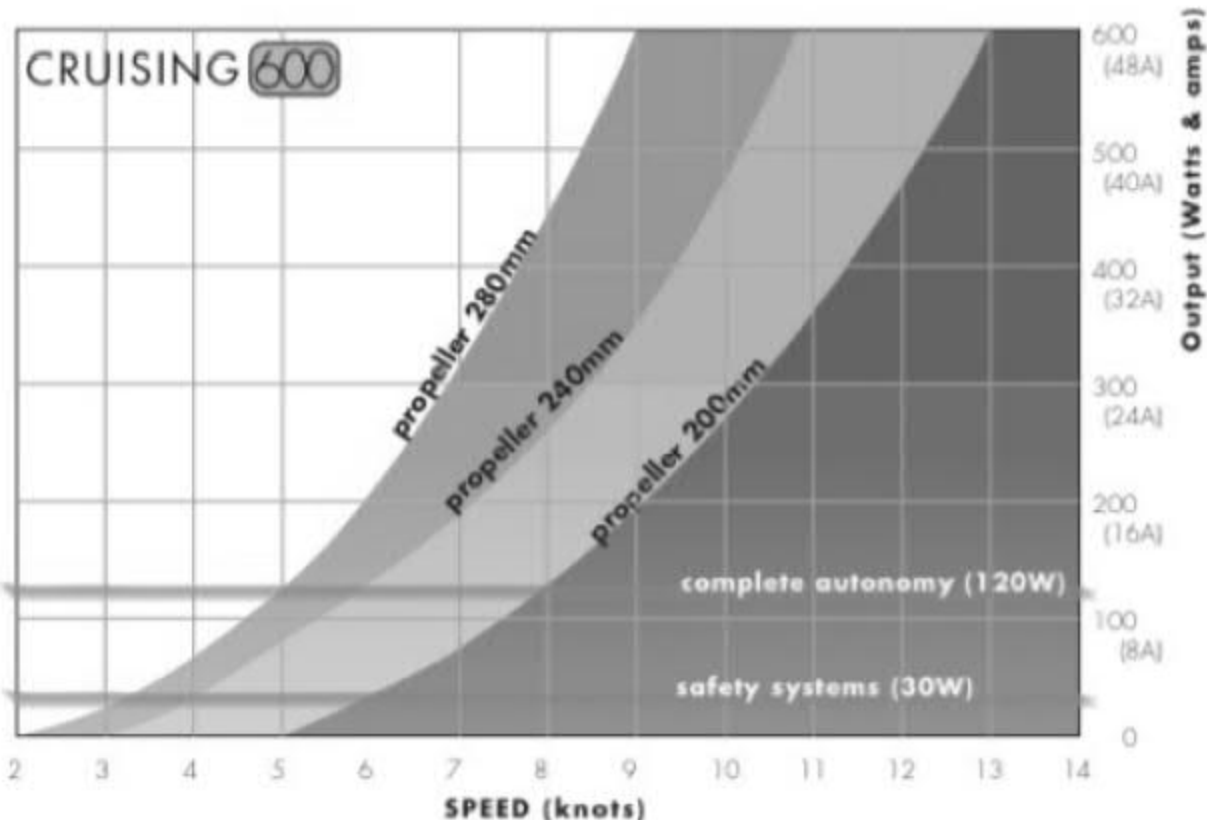

Power output in relation to boat speed

The average production values are given for information purposes only and may vary depending on the sea conditions and the quality of the installation.

8. MAINTENANCE

Originally designed for ocean racing, the hydrogenerator benefits from the latest technology where resistance and reliability are concerned. All metallic parts are made from either specially treated aluminium or A4 stainless steel.

Watertightness is guaranteed using cutting-edge industrial gaskets that have a service life of several thousand hours and can easily support circumnavigation of the globe.

The housing is filled with a lubricating oil to prevent any water seepage.

The hydrogenerator therefore requires no particular maintenance other than cleaning of the external parts.

- The generator housing should be regularly cleaned and rinsed with fresh water.
- Dismont regularly the propeller to clean the shaft from potential dirt.
- The generator and propeller mountings should be regularly inspected to ensure that they are tight.
- Inspect the tightness of the two M6 nuts at the head of the mast at regular intervals
- The electrical connections should be inspected to ensure that they are tight and corrosion-free.
- Check regularly the electrical cable at the exit of the leg (no cuts, pinching).

Watt&Sea recommends servicing every two years or every 10,000 miles. For this, Watt&Sea offers servicing packages tailored to your individual needs. For information visit www.wattandsea.com or contact your distributor.

To ease the return of your hydrogenerator (and reduce shipping cost), it is possible to send the generator only (lower part, without propeller and leg). Please contact us for more information.

9. LIST OF SPARES



Exploded view of a hydrogenerator

REFERENCE	DESIGNATION
G-600-03	Composite generator 600 W (no propeller)
G-300-03	Composite generator 300 W (no propeller)
CV-03	12-24 VCC auto-detected converter
K-03	Lifting bracket with cam cleat
P-200-03	Cruising three-blade propeller, 200 mm (7.9 in)
P-240-03	Cruising three-blade propeller, 240 mm (9.5 in)
P-280-03	Cruising three-blade propeller, 280 mm (11 in)
EP-03	Cruising propeller extraction kit
F-03	Transom mounting kit
FS-03	Upper gudgeon
FI-03	Lower gudgeon
WS-SK-C-001	Pin shaft kit
MA-970-03	Bare aluminium leg 970 mm (38 in) with 2 washers
MA-610-03	Bare aluminium leg 610 mm (24 in) with 2 washers
TM-03	Leg top plate
PI-03	Locking pin

10. F.A.Q

- What power can it produce ?

The power generated depends on the size of the propeller and the speed of navigation.

The table in section 7.4 gives the output power values in relation to speed for different propeller sizes. The average production values are given for information purposes only and may vary depending on the sea conditions and the quality of the installation.

- What drag is to be expected ?

The drag depends on the size of the propeller and the speed of navigation. At 6 knots, we estimate that the average drag is 10 kg. To calculate the loss of speed for a particular boat, you need to compare the total drag of the hull at 6 knots with 10 kg of drag of the hydrogenerator at the same speed. Our immersion and lifting trials at a constant speed have not shown any significant difference on the speedometer.

- What happens when the batteries are charged ?

The electronic regulator automatically charges the batteries. When they are fully charged, the propeller freewheels. And the noise produced by the hydrogenerator changes (thudding sound). Hydrogenerator must then be lifted out of the water (or if installed use the relay to short circuit the three phases and brake the propeller); otherwise you risk irreversible damages on the generator.

- Is the hydrogenerator producing a rumbling sound ?

This means that the batteries are fully charged. The hydrogenerator starts to freewheel and produces a thudding, almost rumbling sound. Hydrogenerator must then be lifted out of the water (or if installed use the relay to short circuit the three phases and brake the propeller); otherwise you risk irreversible damages on the generator.

- Is it possible to use the hydrogenerator with the engine ?

No, the converter will see full batteries and put hydrogenerator in freewheel mode; it is better to lift out of the water the hydrogenerator while using engine. If it is not possible, a relay has to be added to cut hydrogenerator's production.

- Is it possible to use the hydrogenerator in reverse ?

The hydrogenerator must be lifted when reversing the boat in order to avoid any possible damage to the leg and cradle mountings.

- The hydrogenerator does not charge as much as is shown in the charts, why is this ?

The two most common causes of under-production are :

- An electrical connection problem : poorly connected/assembled power socket, damaged/corroded socket, cut or pinched cable.
- The hydrogenerator is positioned along the axis of an appendage (rudder, keel, etc.) which is disrupting the flow of water and affecting production.
- We suggest that you consult the help centre on our website to check that your device is operating correctly : <http://www.wattandsea.com/help-center>

- Do the converter's LEDs consume energy ?

The converter has a residual consumption as one LED is always lit. It cuts out in the event of low voltage (11.9V) in order to save the battery.

- Ion lithium batteries ?

The converter is designed to charge lithium batteries as its voltage is regulated and cannot exceed the maximum value of 14.3 V (or 28.6 V).

It can be programmed with specific voltages, through a computer or mobile application depending on converter's generation, please contact us.

- Sailing in Sargassum?

The hydrogenerator is not designed to cross seas of sargassum. The drag induced by the Sargassum could cause irreversible damage, it is recommended to raise the unit.

- Is the propeller replaceable?

The propeller is simply removed using an M6 extraction screw, supplied in the pack (see chapter 4.5).

11. WARRANTY

Coverage and warranty period: Our products are designed for very specific conditions of use. It is the responsibility of our customers to ensure the appropriate use of our products. Our systems are covered by a two-year warranty against any manufacturing defect. The warranty period starts on the date of purchase of our products by the distributor.

The warranty is limited to the standard replacement of a defective part or, if necessary, the entire system, upon receipt of the part in question. Under civil law, it is the responsibility of the purchaser to fulfil the burden of proof regarding the previous nature of the claimed latent defect.

Any returned systems or parts must be accompanied by the warranty returns form (see below), duly completed as follows: name and address of the customer, date of purchase, type of boat, defective parts, description of the structural or design defect, and description of the conditions under which the system was used.

Returned systems or parts shall only be accepted with the prior written consent of WATT&SEA, and must be returned by prepaid shipment. Should the replacement of the WATT&SEA product prove to be due to a defect covered by the warranty, these shipment costs shall be refunded.

Under no circumstances shall returned systems or parts be refunded; they shall only be repaired or replaced.

Situations not covered by the warranty:

This warranty shall not apply if the system in question:

- has suffered an accident, or undergone unauthorized alterations or repairs;
- has not been installed by a professional installer in strict compliance with the procedure specified by WATT&SEA in the installation and user manual supplied with the generator;
- has been:
 - o installed or serviced in an inappropriate manner, or used under too high a charge;
 - o subjected to abuse or neglect;
 - o used when reversing.

The warranty shall not take into account any failures due to simple wear and tear or normal ageing of the structures and materials, any scratches, or any cracks or starrng that may appear following an impact.

Under no circumstances shall WATT&SEA be liable for any special, incidental or consequential damages.

Should you encounter a problem with your WATT&SEA hydrogenerator, please contact your distributor/installer.

12. FORM FOR REQUESTING AN AFTER-SALES SERVICE RETURN

Owner	
Name:	Phone no.:
Address:	E-mail:
	Country:
Date of purchase of the hydrogenerator: Serial no. (see installation manual) - of the hydrogenerator: - of the converter:	Type of boat: Type of assembly on the transom (if custom-made, please specify):
Conditions of use (frequency/specific conditions having revealed the defect):	
Defect noticed:	
Date:	
Signature:	

Retailer/Installer	
Name:	Phone no.:
Address:	E-mail:
	Country:
Date of purchase of the hydrogenerator:	Has the defect been confirmed?
Has the installation been carried out in compliance with the instruction manual?	Installer contact details:
Defective subassemblies to be replaced:	
Date:	
Signature:	
After Sales returns authorization no.:	