

RevNo	Revision note	Date	Signature	Checked
-------	---------------	------	-----------	---------

A  
B  
C  
D  
E  
F

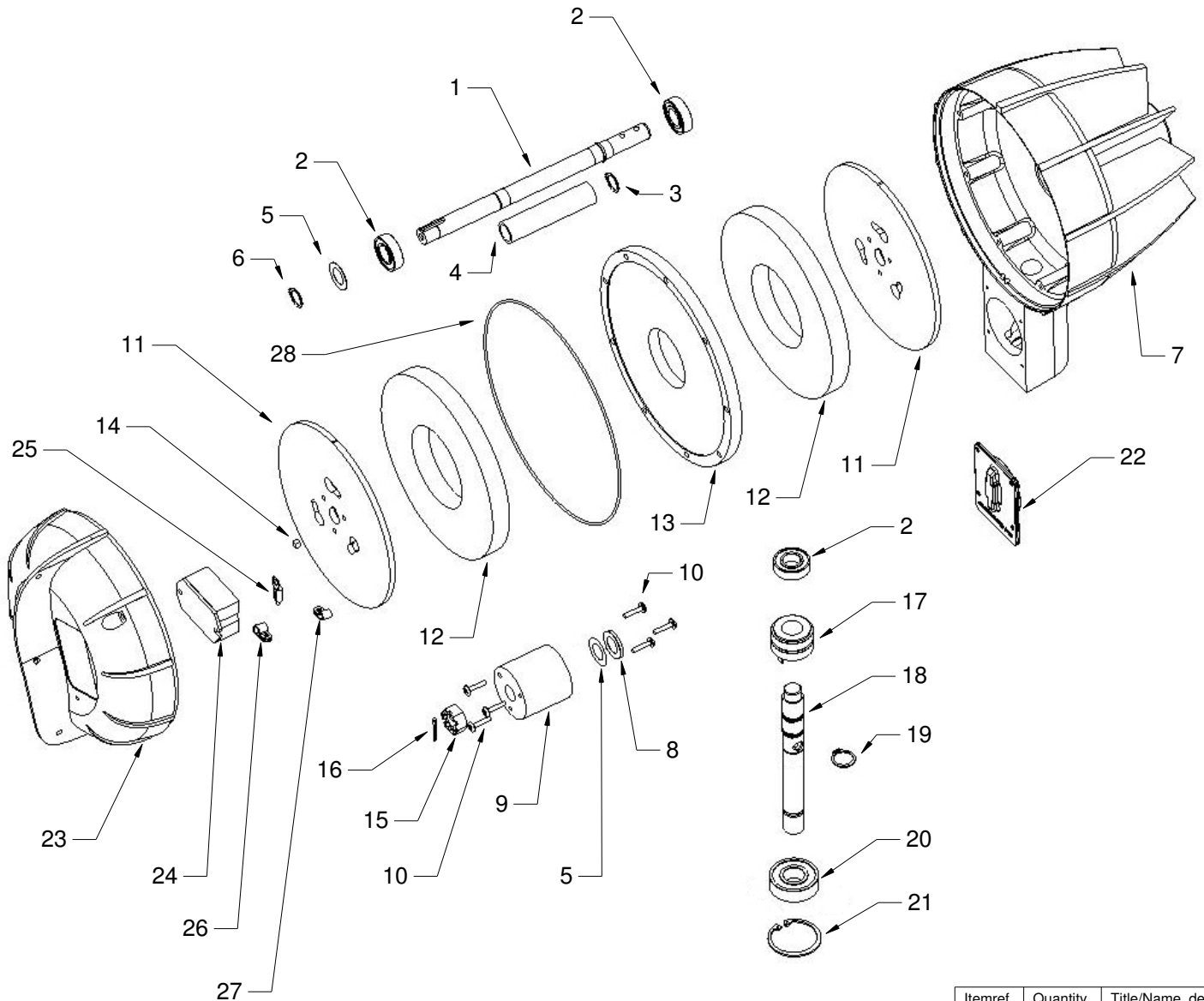

	Part Code	Description
1	10029	Main shaft
2	10295	Bearing 6003ZZ
3	10549	Wavy washer
4	10164	Bearing spacer
5	10159	Shim
6	10031	Circlip
7	10231	Front housing
8	10138	Spacing washer
9	10456	Magnet spacer
10	10460	Screw M5 x 16
11	10173	Pole piece
12	10173	Magnet ring
13	12 V - 90228 24 V - 90229 48 V - 90230	Stator assembly
14	10174	Key
15	10040	Castle nut
16	10187	Split pin
17	10260	Slip ring
18	12 & 24 V - 10494 48 V - 10615	Yaw shaft
19	10281	Circlip
20	10253	Bearing 6204ZZ
21	10282	Circlip
22	10312	Brush housing
23	10232	Back
24	10305	Bridge rectifier
25	10397	Crimp terminal
26	10076	P-clip
27	10192	P-clip
28	10273	O-ring

A  
B  
C  
D  
E  
F

Itemref	Quantity	Title/Name, designation, material, dimension etc	Article No./Reference		
Drawn by	Checked by	Approved by - date	File name	Date	Scale
CEB				8.3.12	
			D400 Exploded Drawing		
			Simplified version	Edition	Sheet