



MOD. FRIGOMATIC AV35F
MOD. FRIGOMATIC AH 35F
MOD. FRIGOMATIC PARIS
MOD. FRIGOMATIC ROMA
MOD. FRIGOMATIC MADRID
MOD. FRIGOMATIC CAPRI
MOD. FRIGOMATIC K35F
MOD. FRIGOMATIC W35F
MOD. FRIGOMATIC K50F
MOD. FRIGOMATIC W50F

USERS' AND MAINTENANCE MANUAL

TABLE OF CONTENTS

CHAP		PAGE
	WARRANTY	2
1	THE FRIGOMATIC 35 F	3
2	FRIGOMATIC Mod. AV 35F - AH 35F	3-4
3	FRIGOMATIC Mod. PARIS , ROMA, MADRID	4
4	FRIGOMATIC Mod. CAPRI	4
5	FRIGOMATIC Mod. "K 35F & K50F"	6
6	FRIGOMATIC Mod. "W 35F & W 50F"	6
7	ELECTRONIC CONTROLLER FOR FRIGOMATIC BD35F & 50F	7
8	ALUMINIUM EVAPORATOR	8
9	THERMOSTAT FOR ALUMINIUM EVAPORATORS	10
10	HOLDING PLATE	11
11	SELF SEALING COUPLINGS	12
12	ELECTRICAL CONNECTIONS	13
13	TROUBLE SHOOTING	15
14	MAINTENANCE	16
15	REPAIR	17
16	TECHNICAL SPECIFICATIONS	19
17	SCHEMATICS	20

NOTICE:

Before starting to install, check that the vessel voltage (12 or 24V D.C.) corresponds to the one marked on the compressor and the electronic unit. Then decide where the different components will be installed by reading carefully the following chapters.

WARRANTY

The warranty card must be filled in by your supplier, stamped and signed by an Frigo boat authorized service station (see point E). You will need to show the warranty card when you want the unit under warranty to be repaired. The authorized service station will take a note of what has been done or of what was suggested on the back of the warranty card. You better keep the card after the warranty has expired: it will help service to know more about your unit.

*** FRIGOBOAT WARRANTY ***

A) WARRANTY

The manufacturer warrants that the products listed in the warranty card are not defective from material and/or workmanship with the limitations specified in the following points. The warranty is valid in the same country where the unit has been purchased.

B) HOW TO EXTEND THE WARRANTY ABROAD

The Frigo boat warranty can be extended to all the countries where a "FRIGOBOAT" distributor is established having the unit checked by an authorized Frigo boat service dealer. The first check is free in the same country where the unit has been purchased, in the town where the service is located and during normal working time. The intervention could be charged if the first check is done abroad. The first check must be noted on the alleged warranty card. The lack of this check is not voiding the warranty but would limit the warranty if the failure or problem arose because of no check done. This check must be done within 60 (sixty) days from the delivery date to the end user. Any updating of the unit happened between the date of purchase and the date of the first check can be charged. In case of need, please apply to the national importer or to the nearest service dealer.

C) PRODUCTION CHANGES

The manufacturer will have the right to change his products without notice and without being obliged to up-date the products already sold and/or manufactured.

D) WARRANTY PERIOD

The warranty starts from the delivery date to the first owner and/or user. The delivery date has to be registered on the warranty card, which has to be completely filled. The warranty term is the minimum term prescribed by the law, if a specific law exists. Where no law on the matter was issued, or the term is a shorter one, the term is of 12 (twelve) months. All the replaced and/or repaired parts will enjoy of the residual warranty term.

E) FIRST CHECK OF THE AUTHORIZED SERVICE STATION

All the products, before being delivered are carefully checked to make sure they meet the Frigo boat specifications and quality standards. The manufacturer is not installing Frigo boat products by herself. Therefore the warranty will be valid only if the Frigo boat unit is inspected and tested by an authorized service station within 60 (sixty) days from the delivery of the unit to the owner and/or user.

F) WHAT IS THE WARRANTY COVERING

The warranty covers the cost of the defective parts or the cost for repairing them or the cost of interchangeable parts for replacement, whatever more convenient. A Frigo boat product or one component part is considered defective, and therefore included in our warranty, when it had a congenital fault existing when delivered. All the repairs under warranty when warranty must be carried out by an authorized service station during normal working hours. Time allowance tables are calculated on an average intervention on a unit installed following our specifications and leaving access for interventions. The time in excess of given time is at customer charge.

G) WHAT DOES'NT THE WARRANTY COVER

The warranty does'nt cover the products damaged because of transportation, installation or repairs or misuse, negligence, normal wear, use of not original spare parts or any other improper use or accident and/or negligence following the instruction of the use and maintenance manual or the installation instructions. The warranty is not valid also if the end user is using the product in a irresponsible way or if changes were made which the manufacturer believes may have caused or increased the damage or if safety and or regulating devices were differently adjusted and/or replaced or if the product was used infringing the law and/or for an use which wasn't foreseen. The warranty is not covering other casual or consequential or connected expenses, as for an example, custom, freight and traveling expenses, unusual expenses due to difficulties reaching the products installed, lack of use, lack of profit, lack of time or property, injuries or damages to other parts of products different from the products described in the warranty card. The manufacturer is not authorizing any third party to assume on her behalf other risks related to the sales of his products than those here expressly indicated.

H) REPORT OF THE FAULT

The owner of the unit has to report the fault of the unit to an authorized service station or to the dealer or to the Veco agent. The fault must be reported as soon as possible; at any rate not later the 14 (fourteen) days since the user has found the unit being defective. The report should include an idea of what is felt wrong. The owner should register the date of the claim.

I) RUNNING THE UNIT FOR THE FIRST TIME

Before you run the unit for the first time please make the checking suggested by the manual at Chapter "Checking and testing procedures".

CHAPTER 1

THE FRIGOMATIC 35F

The "Frigomatic" unit consists of the following components:

- 1) The condensing unit, in one of configuration available: FRIGOMATIC PARIS - FRIGOMATIC ROMA - FRIGOMATIC MADRID - FRIGOMATIC CAPRI - FRIGOMATIC AV - FRIGOMATIC AH - FRIGOMATIC W - FRIGOMATIC K.
- 2) The electronic controller (already connected and installed on the compressor)
- 3) The thermostat for evaporator or holding plate.
- 4) The aluminum evaporator or holding plate
- 5) The device "Frigomatic Master (only for models Frigomatic AV 35F and AH 35F)
- 6) The water pump and relay (mod. Frigomatic W 35F only).
- 7) The keel cooler heat exchanger (mod. Frigomatic K35F only)

CHAPTER 2

FRIGOMATIC MOD. AV 35F AND AH 35F

It consists of the compressor, the finned condenser, the fan, the filter drier, two service valves and two quick connects for assembling the unit with the evaporator.

2.1 - POSITION

The position is chosen keeping in mind that:

A.- The length of the connecting pipe is 8ft (2,8mt) without using the extension pipe (see chap. 11.2).

B.- The unit must be installed with the finned condenser against a wall or bulkhead in which a 4-3/4"x5-1/2" (120x140mm) hole will be cut and through which the cooling air will be blown . This bulkhead serves to divide the cold air from the warm air leaving the condenser. Both compartments on either side of the bulkhead must have sufficiently large opening, 31sq.in. (200cm²), to ensure that there is adequate ventilation. The openings should be positioned in such a way that immediate recirculation of heated air does not occur. Recirculation of heated air causes it to become progressively warmer reducing the condenser capacity, lowering the efficiency of the refrigeration plant, and resulting in an increased power consumption and/or loss of cooling capacity. Do not install the unit free standing in a small compartment and take care that where the discharge air enters a small compartment that it cannot immediately reticulate back through an outlet in the same bulkhead. Avoid also using air which is preheated as a result of being drawn from, for instance, the engine compartment.

2.2 - INSTALLATION

2.2.A -FRIGOMATIC MODEL AV 35F

The easiest way is to hang the unit on the bulkhead through which the air has to be blown. Use the template supplied to mark the position of the fixing screws (four will be sufficient) and the outline of the hole. Once you have cut the opening enter the screws into the wall and hang the unit on by means of the slots on the front face, check if the condenser lines up with the hole and if the latter is the right size; finally tighten the screws until the unit is securely fastened. If the condensing unit cannot be wall mounted, for instance where the appropriate wall is too weak, the alternative is to stand it on its base, flush against the wall, with the condenser finned coil lining up with the 4-3/4"x5-1/2" (120x140mm) hole precisely.

2.2.B -FRIGOMATIC MODEL AH 35F

Cut out a 4-3/4"x5-1/2" (120x140mm) opening in the chosen bulkhead or partition in a position where the condenser of the unit lines up in the centre. Fix the unit down using the four holes in the base and the washers supplied. The condenser frame must seal tight again the hole; we suggest to use a foam rubber extruded tape.



2.3 - GRILL

If the hole and therefore the finned condenser is in a position exposed to physical damage it should be protected by a grill having at least the same cross-section of the condenser. We recommend to use our grill E250115 which allows a sufficient air flow and a good protection to the unit.

CHAPTER 3

FRIGOMATIC MOD. PARIS, ROMA, MADRID

It consists of the compressor, an aluminum-copper condenser, a dryer, a brushless fan with duct adaptor 90 mm, 1 service port and 2 quick connects for assembling the unit with the evaporator.

3.1 - POSITION

Choose the position keeping in mind that:

- A.- The standard length of the evaporator pipe is 8ft (2,5mt). For pipe extension see 7.7.
- B.- The unit will perform better if the discharge air flow is ducted out of the space where the unit is installed. Use a 90 mm dia. duct not exceeding 3ft (1 m) to connect the fan discharge to an adequate vent.
- C.- Do not install the unit free standing in a small compartment and avoid also using air which is

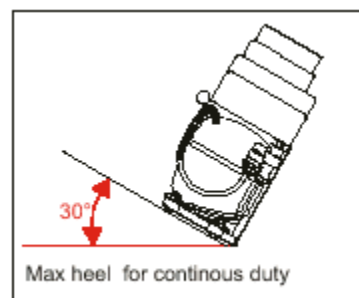

preheated as a result of being drawn from, for instance, the engine room.

CHAPTER 4

FRIGOMATIC MOD. CAPRI 35F

It consists of the compressor, an aluminum-copper condenser, a dryer, a brushless fan with duct adaptor 120 mm, 1 service port and 2 quick connects for assembling the unit with the evaporator.

4.1 - POSITION (Fig. 3.1)

Choose the position keeping in mind that:

- A.-** The standard length of the evaporator pipe is 8ft (2,5mt). For pipe extension see 7.7.
- B.-** The unit will perform better if the discharge air flow is ducted out of the space where the unit is installed. Use a 120 mm Dia. duct not exceeding 3ft (1 m) to connect the fan discharge to an adequate vent.
- C.-** Do not install the unit free standing in a small compartment and avoid also using air which is preheated as a result of being drawn from, for instance, the engine room.

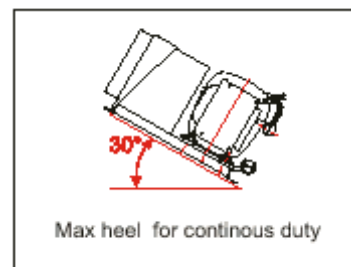

4.2 - HOW TO INSTALL IT

Make a 120-mm. dia hole in the wall. Align the discharge the air outlet against the hole made. Install and fix the Capri using the four holes in the base of the unit.

4.3 - PROTECTING GRILL

If the opening made to discharge the air is at sight, then we suggest to use our optional grill (Cod.E250130) which leaves a sufficient air passage being also of nice design.

CHAPTER 5

FRIGOMATIC MOD. K 35F

It consists of the compressor mod. K, the keel cooler, a dryer, one service port and 2 quick connects.

5.1 - POSITION (see schematic R1033)

The position is chosen keeping in mind that:

- A -** The length of the keel cooler connecting pipes is 3ft (1.5 m) and cannot be extended
- B -** The length of the evaporator standard connecting pipes is 8ft (2,8 m) without using the extension pipe (see 7.7).
- C.-** The compressor can be located any where. It doesn't need air circulation but only accessibility for maintenance.

D.- Fix the unit using the 4 holes in its base. Pay attention to leave enough space for the evaporator and keel cooler connections.

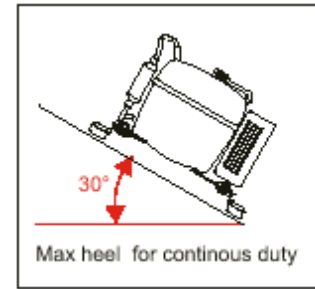

5.2 - KEEL COOLER

The keel cooler exists in 2 versions: Standard and Ground plate. This last has the capability to act as a ground plate for electronic instruments. The keel cooler must be positioned outside the keel drilling a 1 3/4 (40 mm) hole in the keel. Adequate sealant must be used to seal the passage thru the hull. We recommend that the keel cooler is installed far from the area used when lifting the boat. The keel cooler must be protected against corrosion: we suggest to link it to negative and to zinc protection. If the keel cooler is used as a ground plate, it must be inspected periodically to be sure that it is not attacked by corrosion. The standard keel cooler may be protected with antifouling. The ground plate model must not be painted.

CHAPTER 6

FRIGOMATIC MOD. W 35F

It consists of the compressor, the seawater condenser, a dryer, two service valves and two self-sealing couplings.

6.1 - POSITION (Fig. 5.1)

The position is chosen keeping in mind that:

- A.-** The length of the evaporator connecting pipes is 8ft long (2,5mt) without using the extension pipes (see Chap. 7.7).
- B.-** The compressor can be located anywhere provided you would have an easy connection of the evaporator pipes and of the water hoses. You don't need air circulation but accessibility for maintenance.
- C.-** Fix the unit using the 4 holes of the unit feet. Pay attention to have enough space for the water hoses and the evaporator pipe connections.

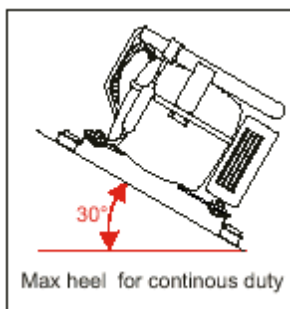

Fig 5.1

6.2 - SEA WATER PUMP

The pump we supply is self-priming. When installing it, make sure that there is a good intake strainer (120 Mesh). Frigoboat part number A091508.

When all connections are completed, operate independently the water pump and make sure that:

- A.- You have no water leaks.
- B.- The water flow is at least 1/2 gall/min (2 l/min).

6.3 - PUMP SPECIFICATION

The pump we supply with the unit is A092819.

12V - 0.8A - water flow: 1 gal/min (4 l/min)

For 24V applications the pump is the same but it needs a special voltage divider (E51385), which halves the voltage (from 24V to 12V).

In connection with the mod. "W" unit any pump can be used provided that.

- A.- The water flow is at least 0,5 gal/min (2 l/min)
- B.- A relay is always used to operate the pump.
- C.- The pump is suitable for continuous duty.

CHAPTER 7

ELECTRONIC CONTROLLER FOR FRIGOMATIC BD 35F

7.1 - The electronic controller has the capacity to transform the 12 or 24V D.C. supply into alternating current on which the compressor runs.

This revolutionary device incorporates also two innovative features:

- a) It works indifferently with 12 or 24V supply and it chooses automatically the 24V if the voltage exceeds 17 V
- b) It can run the compressor from 2,000 RPM up to 3,500 RPM.

The electronic controller has also the following safety features:

7.1.1.-Protection of the battery:

if the supply voltage drops below 10.6 V (23.4) it stops the compressor till the voltage rises back to 11.7 V (24 V). See note 2.

7.1.2 - Protection of the compressor: It stops the compressor, any time it doesn't start when powered; it trys again every 60 seconds. - It will also stop the compressor if its speed is too low (below 1,900 RPM).

7.1.3.- Fan motor and pump protection: if they draw more than 0.7 A, the compressor will be stopped. It tries again every 60 seconds.

7.1.4 - Protection against too high voltage

The electronic controller, if the voltage exceeds 17V, assumes that it is connected to a 24V environment but, in this case (between 17 and 23V) the voltage is too low and the compressor will not run. For this reason with this model of electronic controller (marked as

BD 35F) it must be used a stabilized mains adaptor E51305 which gives always 24V even if the battery supplies 12V.

NOTICE 1: After the electronic unit is powered you could have a waiting time up to 30 seconds, before the compressor starts.

NOTICE 2: The electronic controller, even if designed for marine installation, must be protected against drops of water and from the bilge splashing. Take care that even a single water drop can follow a wire and reach the controller. For this reason we suggest that wires are reaching the controller from a lower position.

7.2 - ALARM SIGNALS

To the electronic controller it is possible to connect a LED (terminals + and D) which emits up to 5 blinks every 5 seconds with the following meanings:

- 1 blink: Supply too low (below 10.4 or 22.8) Check wire size (12.2)
- 2 blinks: Fan (terminals C and F) draws too much (more than .7 A)
- 3 blinks: Compressor failed start attempt (retries every 60 s.)
- 4 blinks: Compressor too low RPM (below 1,900 RPM).
- 5 blinks: Too high temperature of the electronic controller (heat sink) It restarts when it cools down.

CHAPTER 8 ALUMINIUM EVAPORATOR

8.1 - The evaporator is the unit that is installed in the cabinet to cool it and thereby keep it at the desired temperature. Several types of evaporators are available and the choice between them depends on the size and layout of the cabinet. Before starting the installation make sure that the insulation is at least as effective as recommended.

USAGE	POLYURETHANE	POLYSTYRENE
Refrigerator	2 inches (50 mm)	3.3/4 inches (80 mm)
Deep Freeze	4.1/4 inches (100 mm)	6.1/2 inches (160 mm)

A greater thickness is not detrimental and will conserve energy. Under no circumstances use insulation thicknesses below the above recommendations nor exceed the volume specified by more than 10%.

8.2 - POSITION

Install the evaporator as high as possible as cold air falls and therefore the space above the evaporator may not be cold enough for storage. Consider carefully how you will use the cabinet, how you will for instance reach into it and whether you wish to produce ice cubes. The connecting pipe goes out of the cabinet to the condensing unit and requires a hole having a minimum diameter of 1"1/2 (30mm). This hole should be drilled as high as possible to reduce the loss of cold. When selecting the route that the pipe will take, try to choose one that will protect it from damage, by both cutting and compression, even inside lockers, and then drill the necessary holes along that route. Carefully seal the hole you

drilled in your cabinet (consider also the passage of the capillary or thermostat cable).

8.3 - INSTALLATION

The assistance of another person is very useful at this point. Unroll completely the evaporator pipe and arrange the two end couplings so that they will pass one after the other through the sequence of holes that you have prepared, the male coupling (IM) proceed the female coupling (IF). Do not remove the end brass plugs at this stage, as they will provide an important protection from dirt and moisture. Take extreme care of the point where the capillary comes out of the main refrigeration pipe as it is very vulnerable at this point, feed the end of the pipe into the cabinet, out through the hole and then carefully, leading with the hand all the way, through the sequence of holes. Try to avoid inducing force at any stage and keep curves to as large a radius as possible to avoid kinking. Do not keep bending and re bending any section of the pipe as copper work hardens and each successive bend becomes more difficult until the pipe will fail. If you have an excessive length simply roll it up and fasten it to prevent vibrations.

8.4 - EVAPORATOR MODEL "H"

You can install this evaporator in any position.

Drill the four mounting holes in roof or wall of the cabinet. Use two of the four screws provided together with the two studs in the holes in the back or base of the evaporator (closed end), preposition the screws and then slide on the evaporator using the slots. Finally enter the other two stainless steel screws through the holes, then the spacers and hence into the structure of the cabinet. Tighten all screws.

8.5 - EVAPORATOR MODEL "F"

Each one has several holes available for fixing it on the wall of the cabinet lining. For the best performance on the cooling unit these evaporators should be installed with the exit pipe upwards. The evaporator can be bent using the correct tool. Contact a Frigoboat service agent for details.



8.6 - EVAPORATOR MODEL "B"

You can install this evaporator in any position

It has two holes in each corner for a vertical installation on a wall of the cabinet lining. Spacers of 5/8" (16mm) should be used to allow enough air circulation for an efficient cooling.

8.7 - EVAPORATOR PIPE EXTENSIONS

When the compressor has to be placed at a distance over the standard you should use an extension pipe available in length (1-2-3-4-5 and 6 mt long). Use the same care handling

the extension pipe as recommended for the evaporator pipe. The use of long extensions is slightly affecting the unit efficiency.

8.8 - THERMOSTAT CAPILLARY

The evaporator is equipped with a small plate to be used to connect the tail of the thermostat capillary (See 8.5). We strongly suggest to keep this plate accessible and possibly swapping it from one face to the opposite, reversing also the small plastic nut.

8.9 - TOUCHING UP EVAPORATOR PAINT

If the evaporator paint gets dented because of bending or for any other reason, give additional paint touch using epoxy paint. This applies also to the drilled holes.

CHAPTER 9

THERMOSTAT FOR ALUMINIUM EVAPORATORS

9.1 - The thermostat is the component that allows you to regulate the cabinet temperature according to the needs of the stored food.

NOTICE: Vary the thermostat setting when the unit is working or wait 10 minutes since the unit has stopped. If you disconnect the unit while running, wait 5/10 minutes before giving power back again.

9.2 - POSITION

You can place the thermostat either inside or outside the icebox provided you can read it and turn its knob and it is kept well clear of dripping water. The capillary cannot be extended and its end must be in touch with the evaporator (See 9.5)

9.3 - INSTALLATION

Fix the thermostat box on the wall you have chosen using two screws.

9.4 - THERMOSTAT SETTING

The thermostat has a knob graduated from 1 to 7. When the knob is rotated to 7 the temperature in the icebox will become the lowest possible.

9.4.A - THERMOSTAT FOR REFRIGERATION (WHITE BOX)

The first time you start your cooling unit you should rotate the thermostat knob in the position 3-4. You will rotate the knob later towards 7 if you want the temperature in your refrigerator colder and towards 1 if you want it warmer.

9.4.B - FREEZER THERMOSTAT (BLUE BOX)

When starting the unit rotate the thermostat knob to 4. Wait at least two cycles before adjusting the knob for lower or higher freezer temperatures.

9.5 - THERMOSTAT CAPILLARY FOR ALUMINIUM EVAPORATOR (ANY MODEL)

The tip of the capillary should be in touch with the evaporator surface for at least 3" (7.5mm). For this reason you should bend the tip to an "U" shape and place it under the special groove of the small plate on the evaporator before tightening the fixing screw.

ATTENTION : It is important that the thermostat capillary is in contact with the evaporator

at its tip only as other colder contacts could affect the operational characteristics. We strongly suggest that the small fixing plate is easily accessible in order to make future maintenance easily. If necessary the plate can be swapped from one face to the other the evaporator reversing also the plastic nut.



Fig 9.5

9.6 - DEFROST

When frost on your evaporator gets over 1/2 inch thick, switch off the fridge switch or turn the thermostat knob counter clockwise to the "OFF" position and wait till your evaporator is completely defrosted before resetting the thermostat. Open your hatch or door if you want to speed deicing. Never use a knife or other metal object to force ice from your evaporator or you will easily pierce the refrigerant coil sooner or later.

9.7 - EXCESSIVELY COLD CABINET

See Chap. 13 point A.

CHAPTER 10

HOLDING PLATE

10.1 - The holding plate is an alternative to the aluminum evaporator and is installed in the cabinet to cool it. The holding plate has the capacity to store "cold energy" when the compressor is running and to release this cold energy when the compressor stops.

10.2 - POSITION

The plate must be installed vertically as high as possible into the cabinet. The connecting pipe goes out of the cabinet to the condensing unit and requires a hole having a minimum diameter of 1 1/2" (30 mm). This hole should be drilled as high as possible to reduce the loss of cold.

10.3 - INSTALLATION

PLATE 100,140 and 160 : use the special bracket and the template supplied with the plate. The connecting line is supplied loose and therefore, first install the plate and then connect the pipe to the plate.

10.4 - THERMOSTAT

The functioning of the system with the holding plate is controlled by a thermostat (A020300), which senses the holding plate temperature and runs the compressor until the plate is completely frozen. The sensing bulb of the thermostat must be in contact with the holding plate surface in order to sense its temperature (see 11.5).

The thermostat must be set at -10.

CHAPTER 11

QUICK CONNECTS

All the components of the Frigomatic unit are supplied with quick connects which retain the refrigeration gas that has been factory pre charged and permit quick and simply

coupling to form a complete refrigeration system.

IMPORTANT

Under no circumstances run the Frigomatic compressor unless the two quick connects are fully joined.

11.1 COUPLING THE QUICK CONNECTS

The quick connects on the condensing unit are fitted with brass plugs which have to be unscrewed at the very last moment before the two half couplings are brought together. When you have removed the plugs from the quick connects screw one plug into the other and fastens them to the compressor so that they are available at a later date if you wish to disconnect the plant for any reason. Now remove the brass plugs on the evaporator pipe work quick connects and connect the female of the large evaporator pipe with the male placed on the compressor pipe. Centering the two halves precisely, push the two halves together until the nut (D) can be screwed by hand into the male half coupling (IM) and then use two monkey wrenches 13/16" (20mm) and 15/16" (24mm) to screw the nut completely home.

Keep steady with the wrench the male connection: do not let the male end of the quick connect turn. Only tighten until the nut (D) completely covers the male thread (IM) as the sealing mechanism is the 'O Ring' (G) and this is not dependent on the coupling being pulled up excessively tight. If after the coupling has been pushed together you get a continuous hiss take the couplings apart at once as it is possible that the 'O Ring' (G) has been damaged. A spare 'O Ring' is provided. Take care not to bend or twist the two pipes during the above operation and always use two wrenches. Having completed the first coupling you can then proceed with the second one but even more care is required because the capillary tube terminating in a male coupling will not tolerate abuse. Do not let turn the male end of the quick connect. Remember again that a leak proof joint is not dependent on the tightness of the nut but that is important that the nut is screwed up to the full depth of the thread.

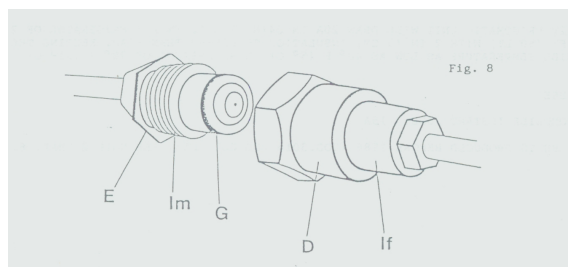

CHAPTER 12

ELECTRICAL CONNECTIONS

12.1 - POLARITY

Use color-coded cable to avoid reverse polarity. Reverse polarity doesn't damage the electronic controller but will not run the compressor. The main panel switch must be new

and of good quality, with minimum power capacity of 20A (10 A for 24V supply). If you use a circuit breaker make sure that it doesn't cause too much voltage drop at start.

12.2 - WIRE SIZE

Measure the length the lead will have between the service control board and the electronic controller. Lead size should be no less than 0,0005 sq.in for each foot length (1 sq.mm for each mt length). We suggest installing a cable having a wire gauge as shown in the following table.

DISTANCE FROM SERVICE BATTERY TO ELECTRONIC CONTROL BOARD			WIRE GAUGE	WIRE SIZE
feet	*	mt	AWG	mm2
up to 6	*	2	14	2
7 to 10	*	2.1 - 3	12	3
11 to 17	*	3.25 - 5	10	5
18 to 27	*	5.50 - 8	8	8
28 to 42	*	8.50 - 13	6	13
43 to 64	*	13.50 - 19	4	19

12.3 - CONNECTIONS TO THE ELECTRONIC CONTROLLER

The electronic unit must be connected only to the battery through a good 15A circuit breaker or a quick acting 15a fuse. Positive (red wire) must be connected to terminal + and negative (black wire) at terminal -.

12.4 - WHAT SHOULDN' T HAPPEN

Bear in mind that the voltage drop occurs across dirty and corroded connectors; never twist wires together but only screw or solder them. A high voltage drop will prevent a compressor starting, will cause erratic running and would also damage the condensing unit if you don't eliminate the voltage drop very soon.

12.5 - THERMOSTAT CONNECTION AND COMPRESSOR SPEED CHOICE

12.5.1 - Frigomatic Paris, Frigomatic Roma, Frigomatic Madrid

These models can run only at 2,000 RPM which gives the best results with the evaporator types supplied for these unit installed in fridges up to 100 litres. The thermostat two wires must be connected to the electronic controller terminals "C" and "T".

12.5.2 - Frigomatic Capri

For the Frigomatic Capri the maximum allowed speed is 2,500 the electronic controller is equipped with the device E51045 which permits the choice between 2,000 and 2,500 Rpm simply connecting the thermostat at C connection and the connection corresponding to the desired speed.

12.5.3 - Frigomatic AV and AH

For these two models it is supplied the device "Frigomatic Master" (E51600) which includes the compressor speed choice and the automatic fan speed control which increases the fan speed as the temperature rises. This control lowers the fan speed as the air temperature is low (night time) and it increases the fan speed as the temperature raises (day time). In the table below we suggest the correct speed for each evaporator model and application (fridge or freezer).

12.5.4 - Frigomatic K - Frigomatic W

These models are supplied equipped with the device E51045 which permits to choose the compressor speed between 2,000 and 3,500 Rpm simply connecting the thermostat at C connection and the connection corresponding to the desired speed. The two thermostat wires can be connected regardless to C or speed terminals.

In the table below we suggest the correct speed for each evaporator model and application (fridge or freezer).

SUGGESTED COMPRESSOR SPEED		
EVAPORATOR TYPE	FRIDGE SPEED	FREEZER SPEED
EVAPORATORE 80 F	2000	-
EVAPORATORE 130H / 130F	2500	3500
EVAPORATORE 160H / 160F	2500	3500
EVAPORATORE 200H/200F/200B	3000	3500
EVAPORATORE 340 B	3500	3500

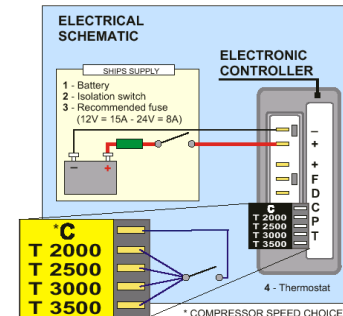

12.6 - FAN CONNECTION

Connect the fan motor to the terminals "F" (- Black) and "C" (+ Red). Do not reverse the polarity. The fan motor is electronically controlled: a short circuit between terminal "C" and "F" or the draw of more than 0.7A would immediately stop the fan motor and the compressor.

NOTICE 1: The compressor and fan could start within 30 seconds after you have powered the controller.

NOTICE 2: All the current and the fuse values must be halved for 24V supply.

12.7 - PUMP (ONLY FRIGOMATIC W WATER COOLED MODEL)

The electric pump motor has to be connected thru a power relay (see schematic R1407). For the installation of two or more "Frigomatic W" units with one pump only, use our pump interface (see schematic R1374).

For 24V installation, the pump must be connected using the voltage divider E252400 (see schematic R1374).

The Frigomatic W35 is equipped with a safety device, which stops the system if the water circulation is not sufficient. This device is installed on the water heat exchanger and must be connected in series with the thermostat. Follow the instructions supplied with the system.

12.8 - VOLTAGE SUPPLY

It is advisable to check the value of the supply voltage at the electronic controller terminals + and - , particularly when the supply comes through the yacht panel. Switch on all loads connected to the service battery and then switch on the fridge unit, after a few seconds the fridge will start and at no time during the starting should the actual voltage have dropped below the nominal 12 or 24V.

CHAPTER 13 TROUBLE SHOOTING

13.1 - TEMPERATURE IS TOO LOW

Chap.	Cause	Diagnosis and Remedy
13.1.1	Thermostat	Turn the thermostat knob on a lower number.
13.1.2	Thermostat	The unit runs continuously without cycling : in spite of the thermostat position. If the evaporator is completely frozen replace the thermostat.
13.1.3	Holding plate is too big (Energy Saving system)	Reduce the cooling surface of the holding plate by using the Mod. A090900 ice cube kit assembly. If the temperature is too low partially cover the remaining surface with insulating material.

13.2 - TEMPERATURE IN THE COOL BOX IS NOT LOW ENOUGH

Chap.	Cause	Diagnosis and Remedy
13.2.1	Thermostat OR Frost on the evaporator	Turn the thermostat knob on a higher number. See Chap. 8.7.
13.2.2	Lack of refrigerant	Evaporator is only partially frozen and the unit runs continuously (See Point 13.5.1).
13.2.3	Cooling unit no big enough	The evaporator is completely frozen conveniently located in the upper side of the cabinet. The cooling unit is cycling also when thermostat is in the position 7 but temperature inside the cabinets is too high. It means that the cabinet is too big for the evaporator or the cabinet insulation is too poor. Should not be convenient for your to increase the cabinet insulation and or replace the evaporator with a bigger one, you can find a remedy by moving the evaporator downwards. Doing so you reduce the refrigerated area : the cabinet size over the evaporator will not be cooled.

13.3 - COMPRESSOR DOESN'T RUN

Chap.	Cause	Diagnosis and Remedy
13.3.1	You are too anxious, not giving enough time to the unit.	Wait at least a minute without disconnecting, the main switch and with the thermostat on position 7.
13.3.2	Wrong connections.	Check connections.
13.3.3	Thermostat switched OFF. OR Wrongly connected. OR Defective.	Check thermostat knob position. Check thermostat connections. Bridge terminal "T" and "C" thermostat. If the compressor then starts, leave the bridge. Run and stop the system using the external (panel) switch (See 11.1.1). As soon as you can replace the thermostat as it is broken. If the compressor doesn't start, call the Authorized Frigoboard Service.
13.3.4	Loose fuse. OR Defective or blown fuse.	Check the fuse on the yacht panel. Check the fuse on the panel and the terminals and replace the fuse if needed. Should the new fuse blow again replace the controller. Do not connect a defective controller to a new compressor. Do not exceed the 15 AMP rated value of the fuse (normal automobile fuse).
13.3.5	Voltage too low.	Charge the battery (run the engine).
13.3.6	Defective controller	If the controller is doing its start attempt every 30 seconds and the compressor is not starting, replace the controller with a new one.
13.3.7	Defective compressor.	If a new controller is not capable to start the compressor check with a tester the electrical continuity between the compressor terminals. Ohm value should be the same for all the terminals of the compressor.
13.3.8	Compressor temperature below freezing temperature.	You have to wait till the compressor temperature rises.

13.4 - COMPRESSOR MAKES START ATTEMPTS BUT IMMEDIATELY STOPS

Chap.	Cause	Diagnosis and Remedy
		Disconnect the unit for 10 minutes
13.4.1	Self sealing coupling non screwed tight	If unit doesn't start after the rest, check the capillary quick connect is screwed correctly.
13.4.2	Voltage drops too low when the unit starts.	Check all connections if loose and/or corroded. Check cables and replace them if undersized.
13.4.3	Fan or pump relay defective. Wrongly connected.	Disconnect fan or pump relay from controller terminals "F" and "C". If the compressor starts after disconnection, replace the fan (or the pump) motor (See 6.1.3).

WARNING: The electronic controller checks the voltage also during the compressor starting attempts. For this reason the wiring should be dimensioned to 15A draw for 12V units (7.5A for 24V).

13.5 - THE COMPRESSOR RUNS - LOW EFFICIENCY

Temperature in the fridge is too high - the evaporator is wet and it freezes partially, close to the capillary inlet.

Chap.	Cause	Diagnosis and Remedy
13.5.1	The unit has a leak	Stop the unit and call for service (See also 15.2 and 15.3).

13.6 - COMPRESSOR TURNS - NO COOLING AT ALL

Chap.	Cause	Diagnosis and Remedy
13.6.1	The unit is empty.	Stop the unit and call for service (See also Chapp. 15.2 and 15.3).

CHAPTER 14**MAINTENANCE****14.1 - AIR COOLED UNITS**

Clean the air condenser at least once a year. A condenser clogged with dust means waste of power (for "W" units see Chap. 14.5).

14.2 - RUST

Use anti-rust materials and paint to protect the components in case they have been attacked by rust.

14.3 - OXIDATION OF ELECTRICAL PARTS

Clean the electrical terminals and contacts but **do not use any kind of spray** as it will surely damage the electronic circuit and void warranty.

14.4 - DEFROSTING (see 8.6).**14.5 - WINTERIZING**

When winterizing W units, rinse the seawater circuit with fresh water before draining it out.

CHAPTER 15**REPAIRS****15.1 - GAUGES**

15.1.A - High pressure gauge: any gauge and service hose when connected to the high pressure side of a cooling system will be filled with liquid refrigerant. Before disconnecting the gauge wait till the evaporator of the unit has been completely frozen. You can disconnect the gauge only when the high and low pressures are equalized (about 10' after a stop) because at this stage all the liquid refrigerant has entered the evaporator. The refrigerant gas remaining in the gauge and in its service hose will not affect the unit charge.

NOTICE: Connect the gauge on the high-pressure side only if strictly needed.

15.1.B - Low pressure gauge: we recommend to disconnect the low pressure gauge only when you have stopped the unit reaching a 0 pressure value in the suction side.

15.2 - SEEKING FOR A LEAK

Before recharging the unit you must find and repair the leak.

15.2.A - Keep the unit under 56PSI - 4 BAR of Refrigerant pressure.

15.2.B - With a reliable leak detector find the leak and fix it.

15.2.C - Should the leak be located on the quick connects replace the "O Ring" with new ones.

15.2.D - If the leak is located on a pipe or on a brazing, before repairing, discharge all the pressure from the unit and remove oxide and oil from the leaking point.

15.2.E - Small leaks on the evaporator can sometimes be successfully repaired with appropriate two components epoxy glue.

You don't find the leak! THIS CAN MEAN :

15.2.F - The unit lost part of the refrigerant charge, when initially installed, for a wrong operation. If so the unit wasn't really efficient since the beginning.

15.2.G - The leak was located on one of the service schrader valve. Replace the gasket inside the caps of the valves.

15.3 - REFILLING THE UNIT

15.3.A - Simplified procedure: This procedure can be followed only if the leak was located in the high pressure side of the unit and the unit had still some kind of cooling efficiency. - Operate the Frigomatic after the gauges and a refilling Refrigerant tank have been connected to the unit suction side. Let the unit slowly suck Refrigerant gas from the tank till the evaporator is completely frozen. To do so, open the refrigerant valve to keep approx. 14 P.S.I. (1 Bar) on the low side. Make this for 1 minute or less and then close the valve and let the unit for at least 5 minutes checking the evaporator freezing. Do it again until you reach the complete freezing. Before disconnecting the gauges and the tank let the unit work with the thermostat knob in the position 3. Verify at least twice if the unit is regularly cycling.

15.3.B - Complete procedure: the leak was in low pressure side. See 15.5. If you do not need to replace the filter dryer, then follow the procedure from 15.5.C. To reach the perfect change, see 15.3.A.

15.4 - OBSTRUCTED CAPILLARY (PARTIALLY)

The unit whilst being recharged, doesn't show any increase of efficiency: it means the capillary is partially obstructed. You could also get an erratic efficiency: it means the obstruction is moving inside the capillary. Unscrew 4,5 turns the quick connect between the dryer and the capillary and operate the unit until you get 0 pressure in the low pressure side. Replace the evaporator: if you don't have one new on hand you can try to repair the evaporator by blowing high pressure (at least 140 P.S.I./10 Bars) of dry air or nitrogen from the capillary quick connect hoping the obstruction will be blown out. If so you should notice by measuring an increase of the air flow of. The repaired evaporator should be reconditioned with Refrigerant before being connected back to the condensing unit.

15.5 - HOW TO DRY AND CHARGE A FRIGOMATIC

You have to dry a unit before charging when:

The unit after a break of a pipe, or a big hole in the evaporator, has run even for a short

period of time or/and remained open to the ambient for over 6 hours.

The procedure we suggest is the following:

A.- Remove the refrigerant dryer.

B.- Install a new refrigerant dryer.

C.- Connect the gauges and the vacuum pump to high and low pressure service valves and evacuate the unit.

D.- Charge the unit with the correct amount of refrigerant shown on the Unit. You don't need to operate the unit for this purpose.

15.6 - PRESSURE VALUES WHEN THE UNIT IS STAYING IDLE

15.6.A - The unit has been stopped since long (24H or more) and all the components are at the ambient temperature: all the refrigerant gas has been occluded in the compressor oil. With ambient temperature between +50/90°F (10/33°C) the pressure in the unit would be 36 P.S.I. +/-7 (2,5 bar +/-0,5)

15.6.B - Unit stopped by the thermostat since 10/15 minutes: the evaporator is frozen, the compressor is hot. Most of the refrigerant in liquid state is included in the evaporator. The pressure in the system will be in the range of 43 P.S.I. +/-7 (3 bars +/-0,5).

CHAPTER 16

TECHNICAL SPECIFICATIONS

* CAPACITY AND CONSUMPTIONS *

MODEL	FRIDGE				FRIDGE			
	2,000		2,500		3,000		3,500	
	BTU/h	Amp	BTU/h	Amp	BTU/h	Amp	BTU/h	Amp
AV 35F - AH 35F (**)	221	3	276	3.6	331	4.5	387	5.7
PARIS 35F (**)	184	3	-	-	-	-	-	-
ROMA 35F (**)	184	3	-	-	-	-	-	-
MADRID 35F (**)	184	3	-	-	-	-	-	-
CAPRI 35F (**)	211	3	264	4				
K 35F (*)	274	2.6	351	3.1	414	3.9	478	4.5
W 35F (\$) (*)	274	2.6	351	3.1	414	3.9	478	4.5

Evaporating temperature : FRIDGE = +5° F/-15°C
FREEZER = -13°F/-25°C

(*) : Condensing temperature: 95°F (35°C)

(**) : Condensing temperature: 113° F (45°C)

(\$) The pump consumption is not included

A 12V Frigomatic unit will draw 20A in 24/H if used in a refrigerator of 2cu.ft (50lt) with 2 in (5cm) insulation of polyurethane foam, keeping the inside temperature as low as 40°F (5°C) in an ambient of 70°F (21°C).

**SCHEMATIC FOR ELECTRIC PUMP ON MODEL W
12volt systems**

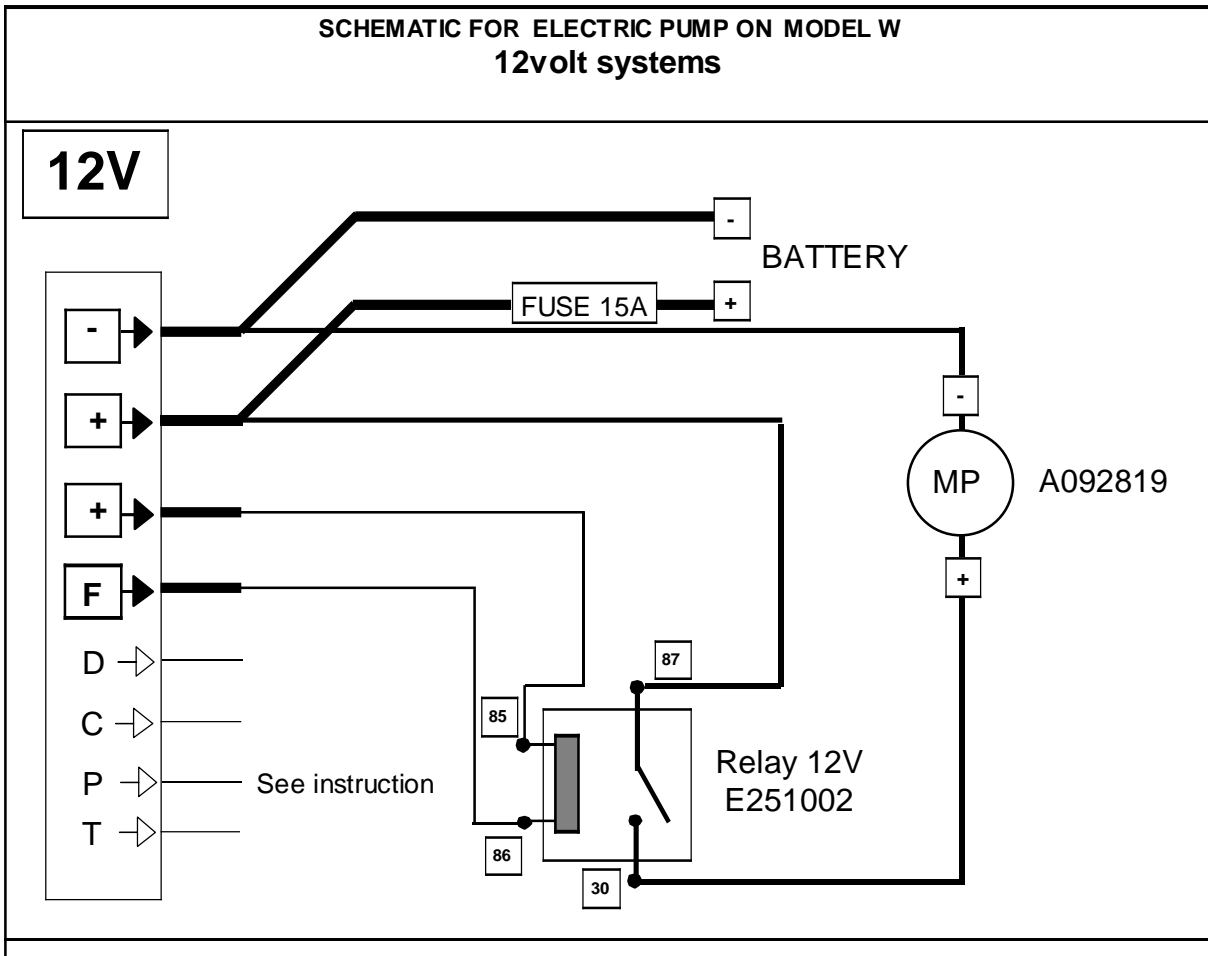

ELECTRICAL SCHEMATIC FOR FRIGOMATIC W 35F AND W50F 12/24 V WITH 1 PUMP AND PUMP INTERFACE E51385

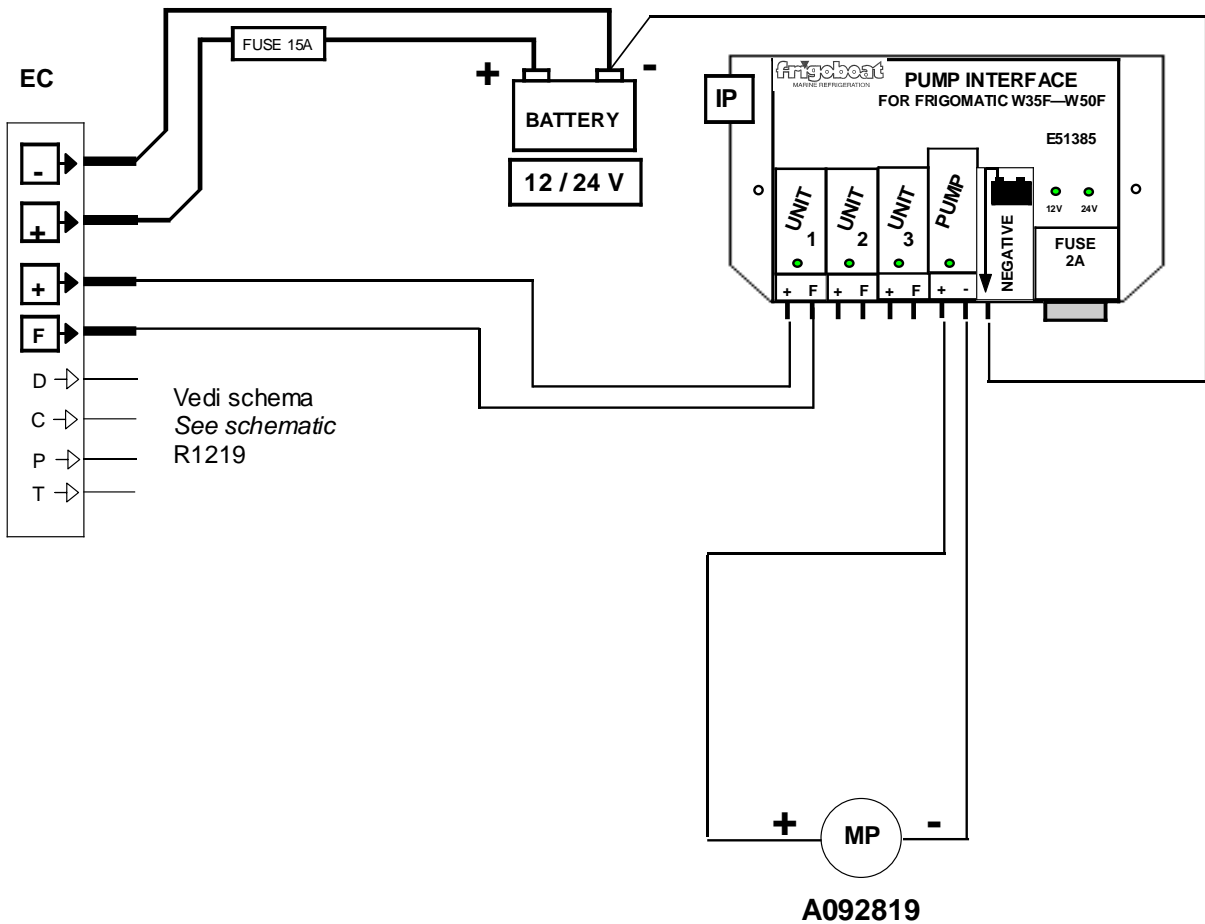

Sezione Size		Max distanza – Max distance			
		24 V			
mm ²	Awg			m.	ft.
2.5	14			5	16.4
4	12			8	26.2
6	10			12	39.4
10	8			20	65.6

EC = Electronic controller - Electronique - Elettronica. E50895
IP = Pump interface - Interface pompe - Interfaccia pompa .E51385
MP = Selfpriming pump - Pompe autoamorcante - Pompa autodescante - .A092819
 Fig.R1413

**ELECTRICAL SCHEMATIC FOR 2 OR 3 FRIGOMATIC W 35F AND W50F
12/24 V WITH 1 PUMP AND PUMP INTERFACE E51385**

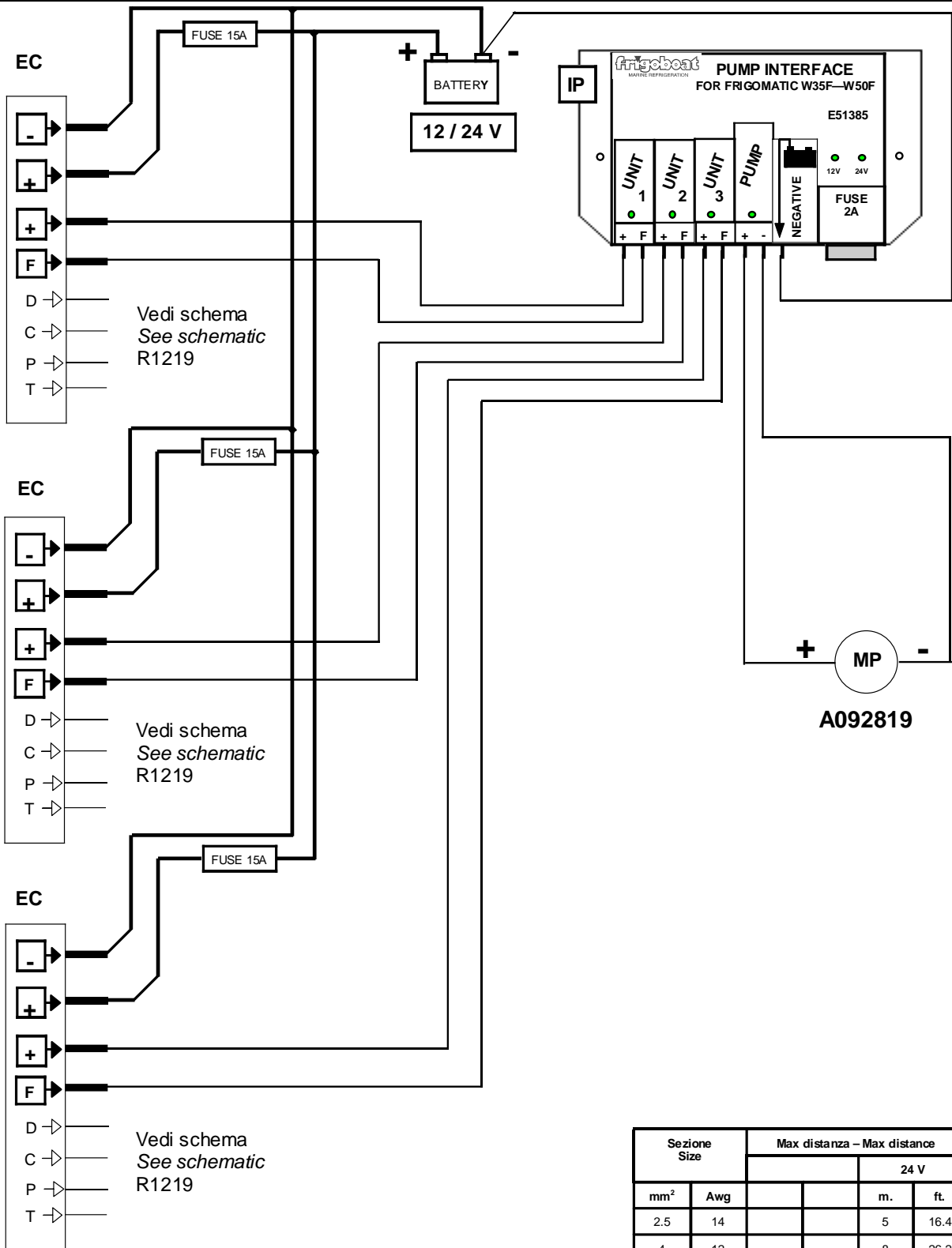

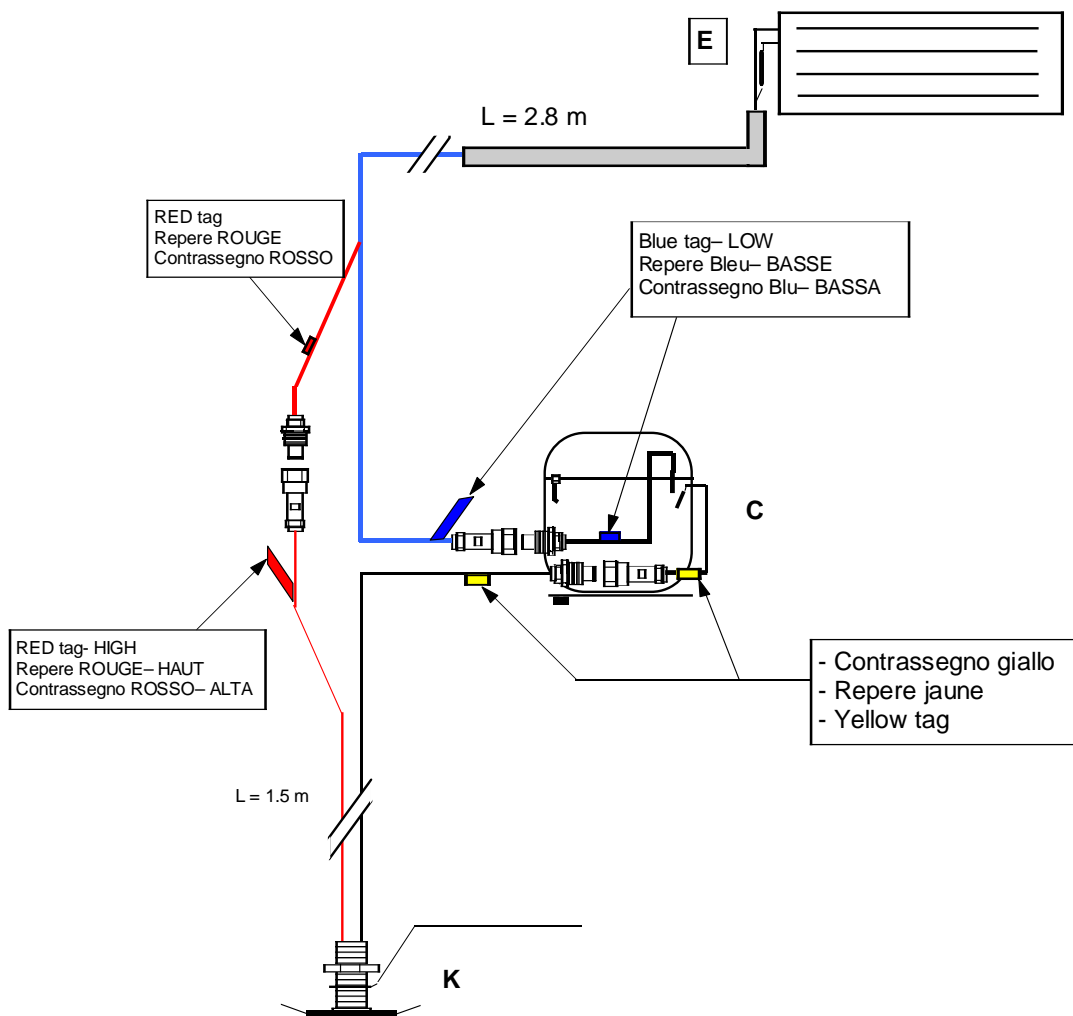

EC = Electronic controller - Electronique - Elettronica. E50895
 IP = Pump interface - Interface pompe - Interfaccia pompa .E51385
 MP = Selfpriming pump - Pompe autoamorcante - Pompa autodescante - .A092819

**SCHEMA DI COLLEGAMENTO PER FRIGOMATIC CON FUORISCAFO.
SCHEMA DE CONNEXIONS POUR FRIGOMATIC AVEC ECHANGEUR DE COQUE.
INSTALLATION LAYOUT FOR FRIGOMATIC WITH KEEL HEAT EXCHANGER.**



- Collegare sempre lo scambiatore fuoriscafo al negativo della batteria. Questo impedisce collegamenti accidentali al positivo.
- Il faut connecter toujours l'échangeur de coque au négatif de la batterie. Ça pour éviter que l'échangeur devienne positif erreur.
- Always connect the keel cooler to the battery negative. This will prevent the plate goes positive by mistake.
- Der Kielkuhler sollte immer mit dem Minuspol der Batterie bzw. mit Masse verbunden sein. Dadurch wird verhindert das der Kielkuhler, durchversehentlichen Kontakt mit dem Pluspol, korrodiert.

- C** = Compressore frigomatic; Compresseur frigomatic; Frigomatic compressor.
- E** = Evaporatore; Evaporateur; Evaporator.
- K** = Scambiatore fuoriscafo; Echangeur hors coque; Keel heat exchanger.
-  = Innesto rapido femmina; raccord rapide femelle; female self sealing coupling.
-  = Innesto rapidi maschio; Raccord rapide male; Male self sealing coupling.

frigoboat
MARINE REFRIGERATION
R1033 01/01

SCHEMA DI COLLEGAMENTO PER SUPER FRIGOMATIC W 50F
SCHEMA DE CONNEXIONS POUR SUPER FRIGOMATIC W50 F
INSTALLATION LAYOUT FOR SUPER FRIGOMATIC W50 F

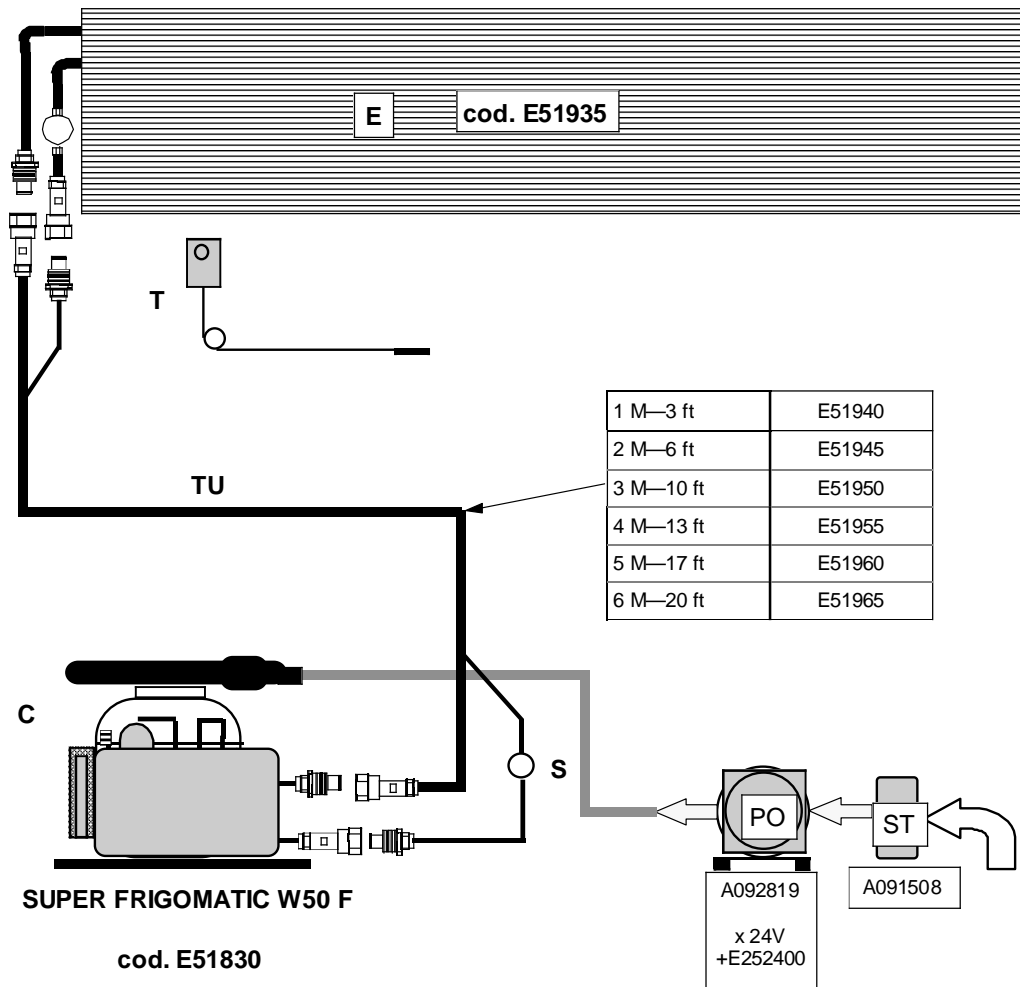

- C = Compressore Superfrigomatic; Compresseur Superfrigomatic; Superfrigomatic compressor.
E = Evaporatore ; Evaporateur; Evaporator.
PO =Pompa autoadescante; Pompe autoamorçante; Self priming pump
S = Spia liquido; Voyant liquide; Sight glass.
ST = Filtro acqua mare; Filtre eau de mer; Sea water strainer
T = Termostato ambiente; Thermostat d'ambiance; Ambient thermostat
TU = Tubazione di collegamento; Tube de connexion; Connecting line

 = Innesto rapido femmina; raccord rapide femelle; female self sealing coupling.

 = Innesto rapido maschio; Raccord rapide male; Male self sealing coupling.

SCHEMA DI COLLEGAMENTO PER SUPER FRIGOMATIC W 50F
SCHEMA DE CONNEXIONS POUR SUPER FRIGOMATIC W50 F
INSTALLATION LAYOUT FOR SUPER FRIGOMATIC W50 F

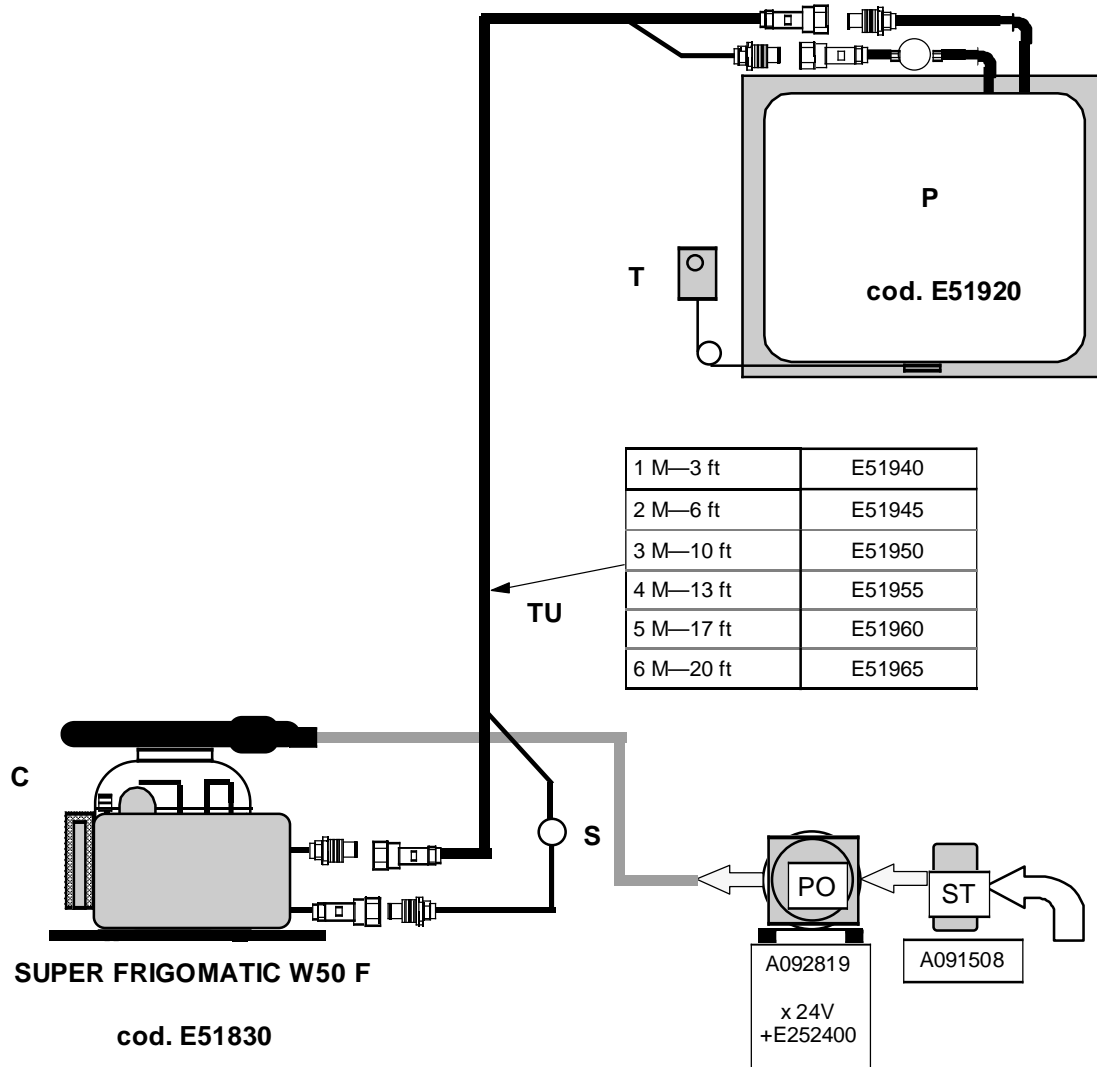

- C = Compressore Superfrigomatic; Compresseur Superfrigomatic; Superfrigomatic compressor.
 K = Scambiatore fuoriscafo; Echangeur hors coque; Keel heat exchanger.
 P = Piastra ad accumulo; Plaque a accumulation; Holding plate.
 PO = Pompa autoadescante; Pompe autoamorcante; Self priming pump
 S = Spia liquido; Voyant liquide; Sight glass.
 ST = Filtro acqua mare; Filtre eau de mer; Sea water strainer
 T = Termostato; Thermostat;

 = Innesto rapido femmina; raccord rapide femelle; female self sealing coupling.

 = Innesto rapido maschio; Raccord rapide male; Male self sealing coupling.

frigoboard[®]
MARINE REFRIGERATION

R1377 10/00